

**NC3** - Automatic Gen.-set Controller for AMF and Mains Parallel Operation

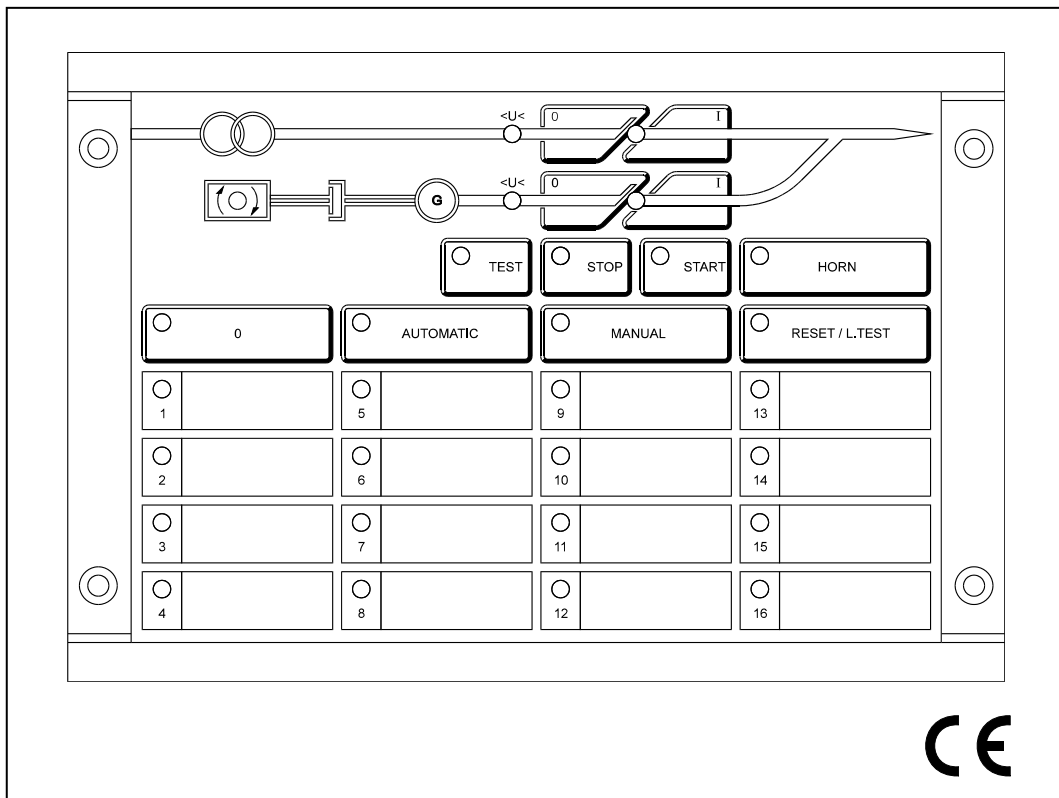

# Contents

## 1 General

## 2 Operation of the NC3

- 2.1 Key functions and operational modes
  - 2.1.1 Operation of the push buttons via digital inputs
  - 2.1.2 Table of operating signals
- 2.2 Overview of Types / Functional Differences
- 2.3 Connections
- 2.4 Description of inputs and outputs
- 2.5 Configuration of connection terminals and coding switches

## 3 Mains supervision

- 3.1 Mains failure/emergency power operation (B7/B8)
- 3.2 Mains voltage supervision
  - 3.2.1 Selection of the rated mains voltage
  - 3.2.2 Overvoltage and undervoltage switching points of the mains voltage supervision
  - 3.2.3 Function of the mains voltage supervision
- 3.3 Mains frequency supervision
  - 3.3.1 Selection of rated frequency
  - 3.3.2 Over- and underfrequency switching points of the mains frequency supervision
  - 3.3.3 Function of the mains frequency supervision
  - 3.3.4 Minimal input voltage for evaluating the frequency
  - 3.3.5 Static and dynamic frequency deviation
- 3.4 Supervision of mains voltage unbalance
- 3.5 Switching-on delay of the mains CB
- 3.6 Circuit breaker supervision during mains reconnection
- 3.7 Synchronization supervision (NC3-1)
- 3.8 Switching over delay in test mode

## 4 Generator supervision

- 4.1 Generator voltage supervision
  - 4.1.1 Rated generator voltage
  - 4.1.2 Function of the generator voltage supervision
  - 4.1.3 Voltage regulating time
- 4.2 Generator frequency supervision
  - 4.2.1 Rated generator frequency
  - 4.2.2 Function of the generator frequency supervision
  - 4.2.3 Other settings of the generator frequency supervision
- 4.3 Switching-on delay of the generator CB
- 4.4 Additional generator voltage supervision

## 5 Genset control

- 5.1 Aux. Voltage supply
  - 5.1.1 Aux. Voltage failure
- 5.2 Definition of the battery type and rated battery voltage
  - 5.2.1 Internal supervision of the battery voltage (B13/B14)
  - 5.2.2 Setting of the battery undervoltage switching points
  - 5.2.3 Setting of the battery overvoltage protection
- 5.3 Start cycle
- 5.4 Start preparation / Start blocking
- 5.5 Emergency start B24
- 5.6 Dynamo and "Genset Running" indication (B17)
  - 5.6.1 Adjustment of the additional excitation
- 5.7 Speed supervision
  - 5.7.1 Signal "Ignition Speed"/"Engine Running"
  - 5.7.2 Overspeed protection
  - 5.7.3 Total speed sensor defect
- 5.8 Start repetition/Start failure
- 5.9 Time circuits
  - 5.9.1 Explanation of the terms used

## 6 Supervision circuits

- 6.1 EMERGENCY STOP (B18)
  - 6.1.1 Internal supervision circuits (signals 1, 3, 6)
  - 6.1.2 External supervision circuits
  - 6.1.3 Configuration of supervision circuits (Alarms)
  - 6.1.4 Explanations to supervision circuits
- 6.2 Reset of alarm signals
  - 6.2.1 Allocation of internal supervision circuits to common alarms 1 - 3
  - 6.2.2 Alarm time

## 7 Inputs

- 7.1 Function matrix for configurable inputs
- 7.2 Emergency start
- 7.3 Parallel operation
  - 7.3.1 Start without mains failure
  - 7.3.2 Switching in parallel
  - 7.3.3 Genset load test without power supply interruption
  - 7.3.4 Automatic changeover after AMF operation
- 7.4 Sprinkler operation
- 7.5 Remote control

## **8 Outputs**

- 8.1 Definition and switching capacity of configurable outputs
- 8.2 Function matrix of configurable outputs
  - 8.2.1 Common alarm
  - 8.2.2 Load stage control
  - 8.2.3 Alarm output
  - 8.2.4 Common alarm 2/Battery voltage too low

## **9 Survey of Parameters**

- 9.1 Possibilities for parameter setting at the unit
- 9.2 Possibilities for parameter setting by means of software
- 9.3 Indication of actual measuring values

## **10 Application for pump sets (NC3-3)**

## **11 Installation**

## **12 Technical Data**

## **13 Order form**

- 13.1 Order code
- 13.2 Accessories



Controller *NC3* comprises electrostatic sensitive components. When removing the cover at the rear precautions against electrostatic discharges have to be taken and regulations of EN 100 015, part 1, to be observed.

This manual is valid for controller software version from P1.08 onwards (see type plate of controller).

# 1 General

The **NC3** is an efficient automatic controller for the parallel operation of gensets with the mains, including function for emergency power operation (type NC3-1). By NC3-2 the control of several gensets operating in parallel is realized.

By these controllers, combustion engines can automatically be started, stopped and supervised. There is no programming involved for adaption to the different gensets, which is an advantage when compared to SPS controls.

For the control of pump sets, automatic controller NC3-3 is used.

Protection of the generator can also be realized by the integrated analogue value processing facility. Here this function provides supervision of mains and generator voltage and frequency as well as supervision of mains unbalance, ignition speed and overspeed, dynamo, speed sensor and battery undervoltage and overvoltage.

Dependent on the operational mode selected, the mains and generator CBs are controlled either manually or automatically.

For the diesel and gas engine start program a variety of adjustable time circuits is available. The basic parameter setting is in accordance with DIN 6280 or VDE 0108. By the EEPROM memory it is ensured that all set parameters are safeguarded.

Comprehensive supervision of mechanical and electrical components of the prime mover, the generators and the switchgear is guaranteed by the galvanically isolated binary alarm inputs of the controller.

With the **NC3** not only short-time parallel operation with CB overlapping (synchronized changeover after test operation) is possible but also long-term parallel operation (peak load operation).

For long-term parallel operation our automatic controllers NP and **NC3** can be recommended.

With only little alterations the **NC3** can be used as replacement for NC2. It is compatible with regard to installation and functions.

## Features and Benefits:

- Housing designed for flush door mounting
- Vibration proof
- Oil and fuel proof
- Connection by plug-in and screw connectors
- Foil keyboard (in IP54)
- Symbolized diagram of the power part at the front (i.e. of Mains, Generator, CBs, Prime Mover, Consumers)
- Remote operation (start, parallel operation, change of operational modes etc.)
- Special functions:
  - two-step load control
  - synchronization supervision
  - Sprinkler operation etc.
- Galvanical isolated input circuits
- Function Matrix for alarm inputs
- 8/16 alarm indicators with first-up indication, 5/13 of which with freely useable inputs (function matrix) and 3 internal supervision circuits
- Function Matrix for outputs (three common alarm outputs)
- All control outputs are designed as high rated potential free contacts (16A or 6A)
- Function and equipment according to DIN 6280-13 or VDE 0180
- Wide-range power supply (12V and 24V batteries)
- Of latest microprocessor technique
- SMD technique
- Self supervision
- User-friendly adjustment by switches and coding plugs or parameter setting software
- Extendable by speed module DB1 for speed detection via pick-up or dynamo
- Indication of speed sensor failure and cable break.
- Equipped with communication software „NC3-Soft“ (RS232)
- Short-term storage of operational modes in case of aux. voltage failure

## 2 Operation of the NC3

All elements and indicators needed for operation of the **NC3** can be found on the foil keyboard at the front of the unit.

In the following chapter the operational elements are briefly explained.

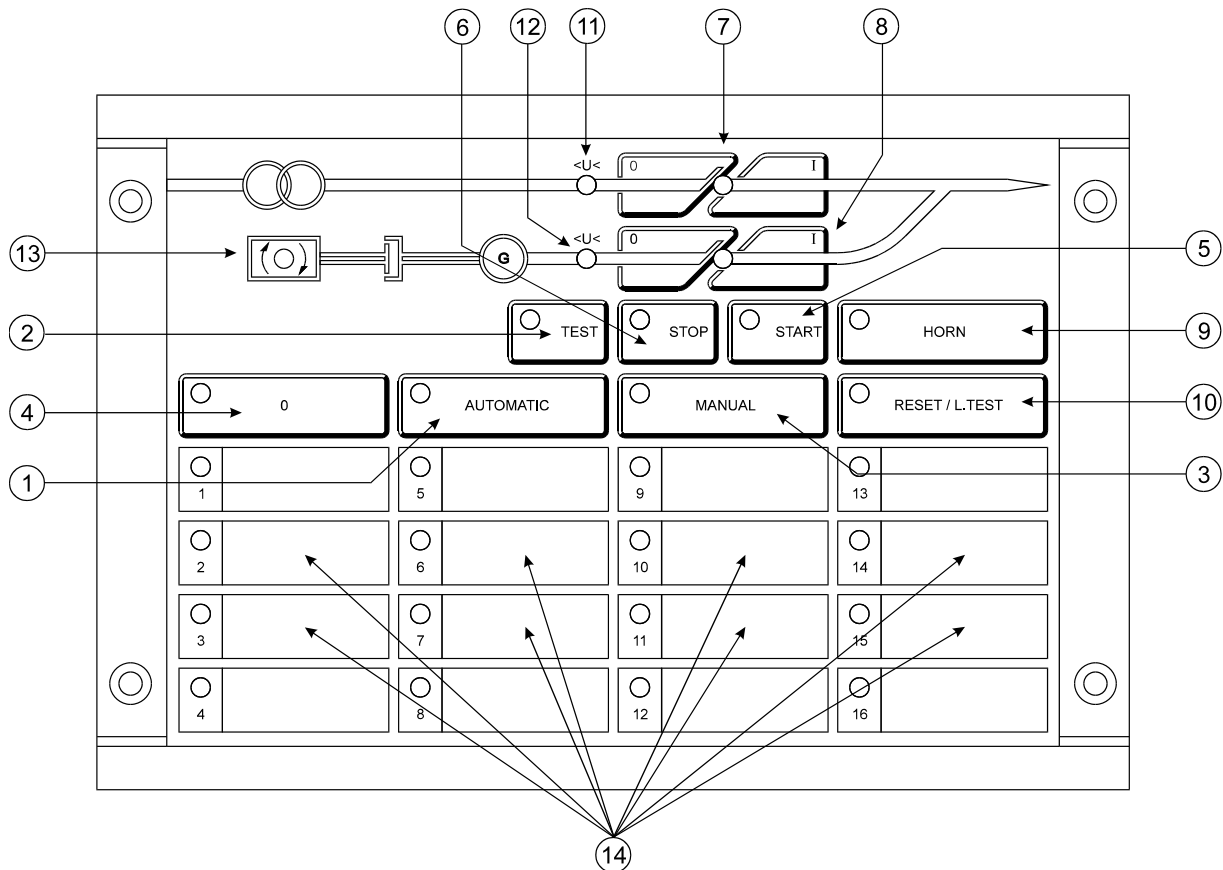

Figure 2.1: Front view

### 2.1 Key functions and operational modes

#### ① AUTOMATIC

When mode **AUTOMATIC** is selected, the automatic emergency operation of the genset is activated. In case of mains failure the genset is started automatically, the mains CB is opened and the generator CB closed. The consumers are then supplied by the generator.

When the mains is restored, the consumers are changed over to the mains automatically, the mains CB is closed and the generator CB opened. Thereafter the consumers are supplied by the mains again. After a certain recooling time the genset is stopped.

In this mode both short-term as well as long-term parallel operation of several gensets or genset/mains is possible (see chapter 7.3).

Selection of a different operational mode can be blocked (see chapter 7.5).

An automatic start of a pump set with NC3-3 (pump set control) very often is initiated by either mains failure or level control (input D2); see chapter 10).

## ② TEST

In this mode no-load and load test run of the genset is possible. In mode TEST, the engine is automatically started and supervised and it is checked whether the generator has reached its rated voltage. At first the generator runs without load, push-button I/O of the mains and generator CBs are active. The mains CB can manually be switched off and the generator CB switched on. The consumers are then supplied by the generator (load test). By pressing "Generator CB On" a load test can automatically be initiated and so there is no release of the mains CB; release of the generator CB is activated after the changeover period (0.5s). Whereas in load test operation release of the generator CB can be deactivated by pressing the "Mains CB On" push-button.

As soon as there is no "Generator CB On" check-back signal, the power supply of the consumers is interrupted for the changeover period and then release of the mains CB activated.

Should a mains failure occur during this time, the mains emergency operation is initiated automatically. After mains restoration, changeover to mains operation can either be made manually or by change to operational mode AUTOMATIC.

## ③ MANUAL

By pressing push-button MANUAL, the manual operation is selected. In this operational mode the **NC3** does not react to mains failure or mains restoration. The genset can be started manually by push-button START and stopped by push-button STOP.

By pressing push-buttons START and MANUAL at the same time, manual pre-glowing of the engine is possible.

Changeover from mains to generator power supply (switching off the mains CB and switching on the generator CB) can only be done manually.

## ⑤ START

By pressing push-button START, the genset is started. This push-button is only activated in operational mode "MANUAL" and has to be pressed until the start-up speed is reached. After reaching the dynamo threshold voltage or the ignition speed, or the generator undervoltage switching point, the starter relay de-energizes and the genset is started.

## ⑥ STOP

By pressing push-button STOP, the generator CB opens and the genset is stopped immediately. The STOP push-button has precedence over the START push-button and is only activated in operational mode MANUAL. The STOP command remains active throughout the stopping time.

## ⑦ MAINS CB I/O

This push-button combination is active in operational modes MANUAL, TEST and OFF; push-buttons I and O are also active when mains voltage is not available. Interlocking of mains CB and generator CB is realized by software. From external the circuit breakers have additionally be interlocked by their check-back contacts.

The internal software interlocking function can be neutralized by applying L- to input D1.

Controller NC3-3 is not provided with a mains CB control.

## ⑧ GENERATOR CB I/O

This push-button combination is only active in operational modes MANUAL or TEST when generator voltage is available. Interlocking of generator CB and mains CB is realized by software. From external the circuit breakers have additionally be interlocked by their check-back contacts.

For short-term parallel operation, the internal software interlocking function can be neutralized by applying L- to input D1.

Controller NC3-3 has no generator CB control.

## ④ 0 (Off Push-Button)

This push-button has precedence over all other push-buttons. If the consumers are supplied by the generator, they are switched over to mains supply upon pressing push-button 0. The mains CB is switched on automatically and can manually be switched on/off via push-buttons MAINS CB I/O. A STOP command is given to the genset. Push-button 0 is also used to cancel the acoustical signal and reset LED "HORN" after fault occurrences. Together with all shut-down and warning signals, the "RESET/L.TEST" LED is suppressed. Indicating signals remain active as long as the fault has not been cleared.

## 9 HORN

By pressing this push-button, the horn is switched off. All warning and shut-down alarms as well as fault indications with warning or shut-down function are indicated by this acoustical signal. With the exception of the first-up indication, all existing alarms are indicated by continuous light after push-button HORN has been pressed. After 5 minutes the acoustical signal is switched off automatically.

## 10 RESET/L.TEST

By this push-button all alarms as well as faults which have caused failure indication are reset. Shut-down and warning alarms which are still active cannot be reset. Reset of the first-up indication is only possible after all shut-down alarms have been reset. The HORN can also be switched off by this push-button. If this push-button is pressed for about 1 s, test of all LEDs is initiated. (see chapter 7.1).  
If this push-button is pressed for about 3 s, test of all LEDs is initiated.  
By this function an output can be controlled and therefore be used for reset and lamp test of operating components (see chapter 7.1).

### 2.1.1 Operation of the push buttons via digital inputs

(Only at NC3-1-8-P and NC3-1-16-P)

The above mentioned devices have the possibility to control the push buttons at the front plate via digital inputs. This can be done by potential-free contacts or a PLC.

The maximum length for unscreened cables is limited to 5 m.

The push buttons are operated by connecting the inputs F1 – F12 to F13 or F14 by means of potential-free NO. contacts.

The signal duration should be between 1-2 s. Simultaneous switching of several inputs must be inhibited by a control logic.

Note:

The device has no input for a C.B. position check-back nor for a actuators. This has to be taken into consideration when using a PLC.

## 2.1.2 Table of operating signals

LED	LED off	LED flashes	LED on
0 ④	Mode "0" not selected	Flashes slowly during Emergency Stop	Mode "0" selected
AUTOMATIC ①	Mode "Automatic" not selected or Emergency Stop	Not applicable	Mode "Automatic" selected
TEST ②	"Test" mode not selected or Emergency Stop	Not applicable	Mode "Test" selected
MANUAL ③	Mode "Manual" not selected or Emergency Stop	Not applicable	Mode "Manual" selected
Mains <U> ⑪	No mains voltage available	Flashing slowly: At mains failure until start delay has expired and at mains restoration until the mains restoration time has elapsed. Flashing quickly: At under/overfrequency and at under/overvoltage. At failure during switching back to the mains quickly alternately flashing in turn with mains CB LED ⑦. There is no mains CB check-back signal.	Mains voltage available, no mains failure.
Mains CB I/O ⑦	Mains CB switched off and check-back signal is received	Flashing slowly: Neither switched-on nor switched-off signal applied. At failure during switching back to the mains quickly alternately flashing in turn with LED ⑪. There is no mains CB check-back signal.	Mains CB switched on and check-back signal is received.
Engine running ⑬	Engine is not running	Flashes slowly: for the time between reaching the ignition speed and elapse of the delayed supervision time. After stop command until falling below the ignition speed and elapse of the engine running reset delay.	Engine is running and time of the supervision delay has elapsed.
Gen. <U> ⑫	No generator voltage present	Flashing slowly: After exceeding the under-voltage switching point at rising generator voltage until elapse of the generator CB release time. At stop command until falling below the undervoltage switching point. At generator voltage fault while the generator CB is still activated until switching off of the generator CB. Flashing quickly: At under/over-frequency and under/overvoltage in case of generator voltage fault.	Generator voltage available and generator CB release time has elapsed.

LED	LED off	LED flashes	LED on
Gen. CB I/O ⑧	The generator CB is switched off and the check-back OFF signal is received.	Flashing slowly: There is no switching on/off check-back signal.	The generator CB is switched on and the check-back ON signal is received.
START ⑤	When start procedure is completed or the genset switched off.	Flashing slowly: During start intervals.	As long as the starter is activated.
STOP ⑥	The genset is not in operation or the stopping time has elapsed.	Flashing slowly: During recooling time.	During genset stopping procedure
HORN ⑨	There is no fault signalled or push-button HORN has already been pressed after a fault was signalled.	Does not flash.	In case of warning or shut-down signal, EMERGENCY STOP, or mains supervision fault, either until push-button HORN or RESET/L.TEST is pressed; otherwise for 5 minutes.
RESET/L.TEST ⑩	There is no fault signalled or push-button RESET/L.TEST has already been pressed after fault clearance.	Does not flash.	Before RESET/L.TEST push button was pressed, a warning or shut-down alarm was signalled, or EMERGENCY STOP or failure during switching back to the mains.

Table 2.1: Overview of the operating signals

## 2.2 Overview of Types / Functional Differences

For systems in single operation, multiple systems operating parallel with the mains and systems with several coupling points, the integrated mains supervision NC3-1 is not needed. For such applications the NC3-2 without mains supervision and mains CB control is used.

Type NC3-3 is designed for control of pump sets. It is also provided with a mains supervision and has an input for starting the pump set via an external level control.

Type	Signal inputs	Gen set control	AMF Operation	Mains parallel operation	Pump set control
NC3-1-8	8		•	•	
NC3-1-16	16		•	•	
NC3-2-8	8	•			
NC3-2-16	16	•			
NC3-3-16	16	•			•

Table 2.2: Overview of types

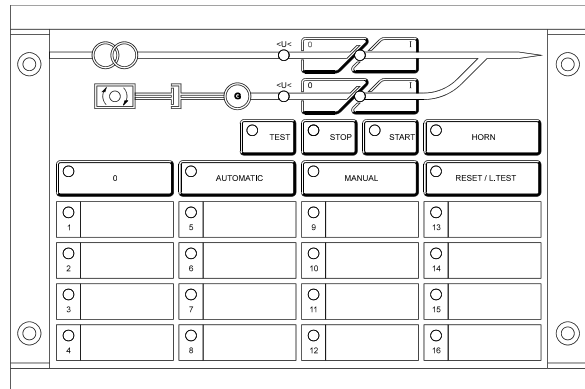

Figure 2.2: Frontplate of NC3-1-16

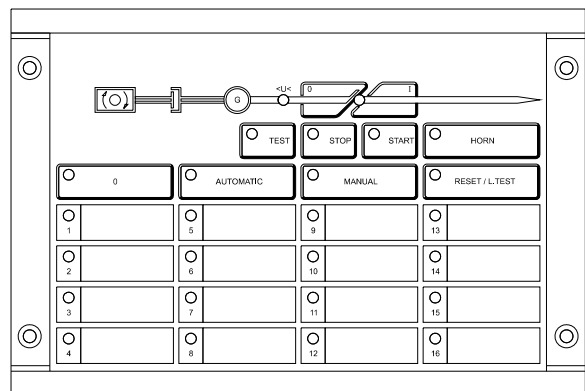

Figure 2.3: Frontplate of NC3-2-16

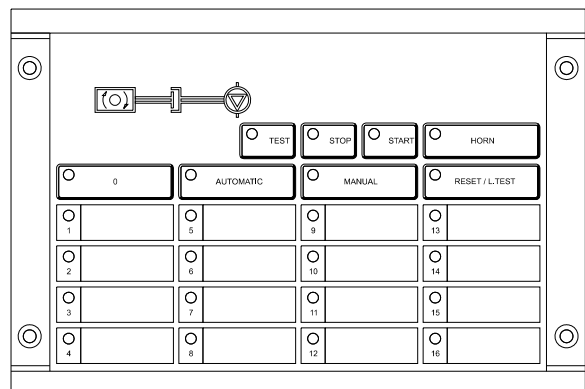

Figure 2.4: Frontplate of NC3-3-16

## 2.3 Connections

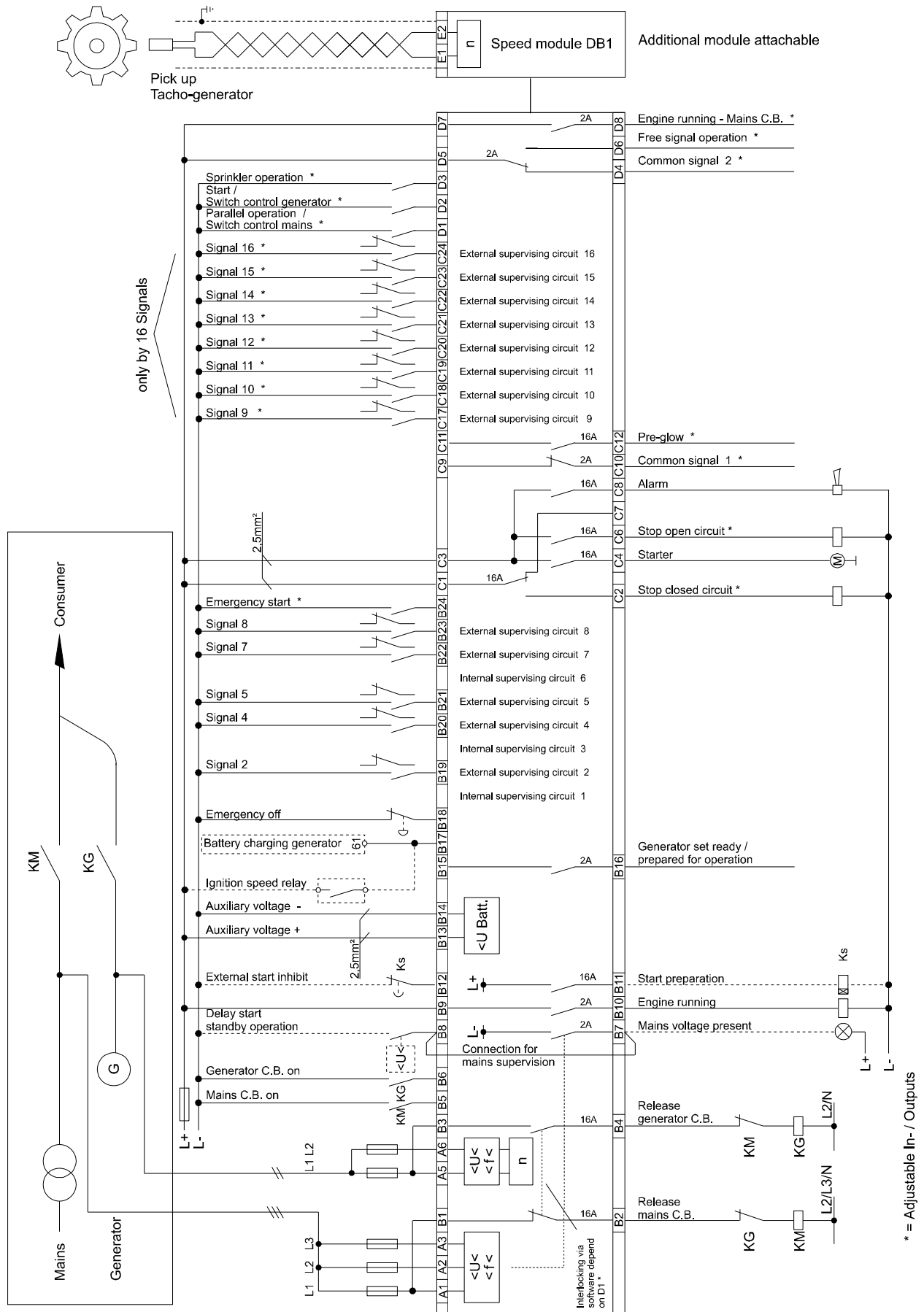

Figure 2.5: Connection diagram NC3-1-16 (for type NC3-1-8 inputs C17 - C24 do not apply)

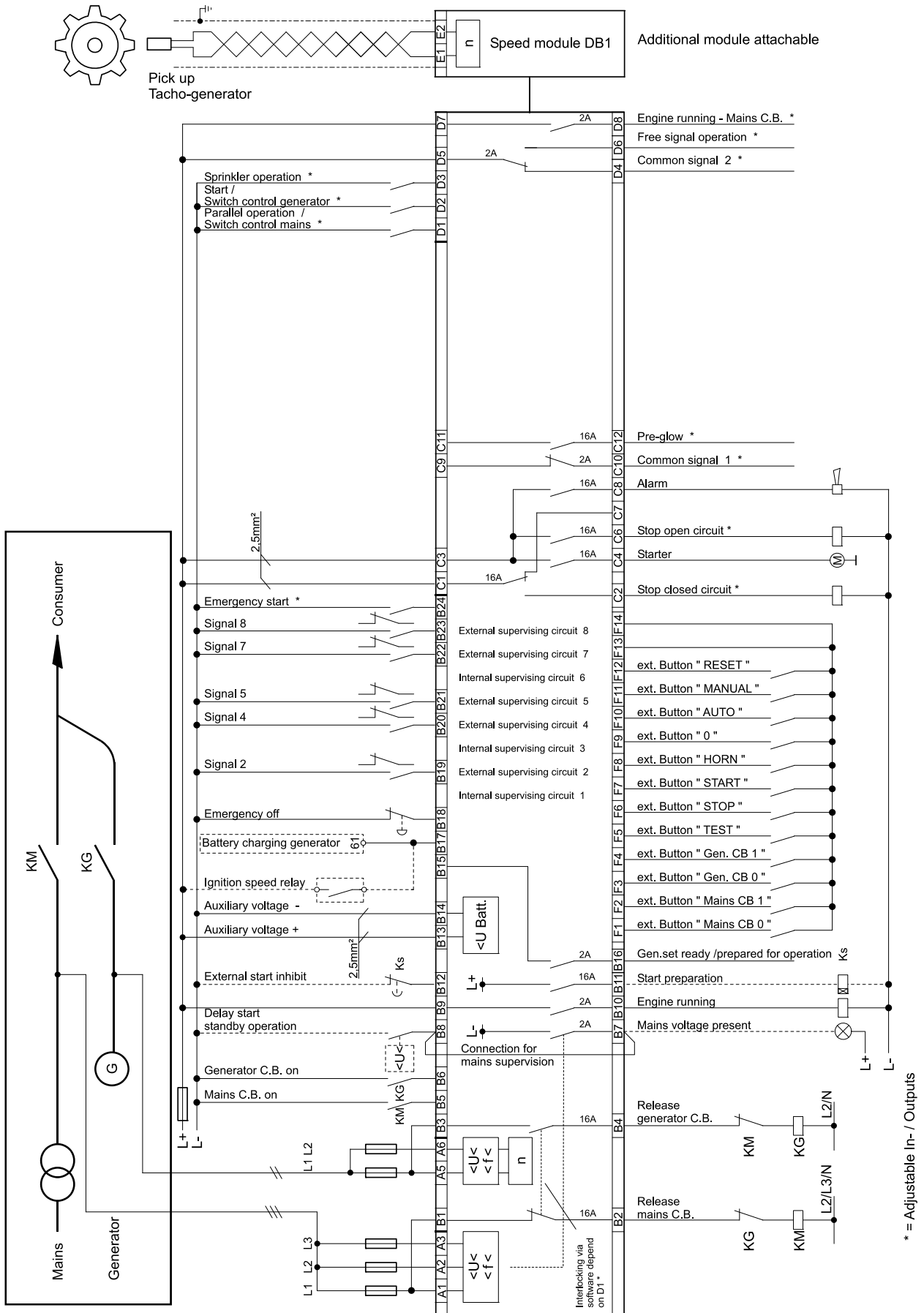

Figure 2.6: Connection diagram NC3-1-16-P (for type NC3-1-8 P inputs C17 - C24 do not apply)

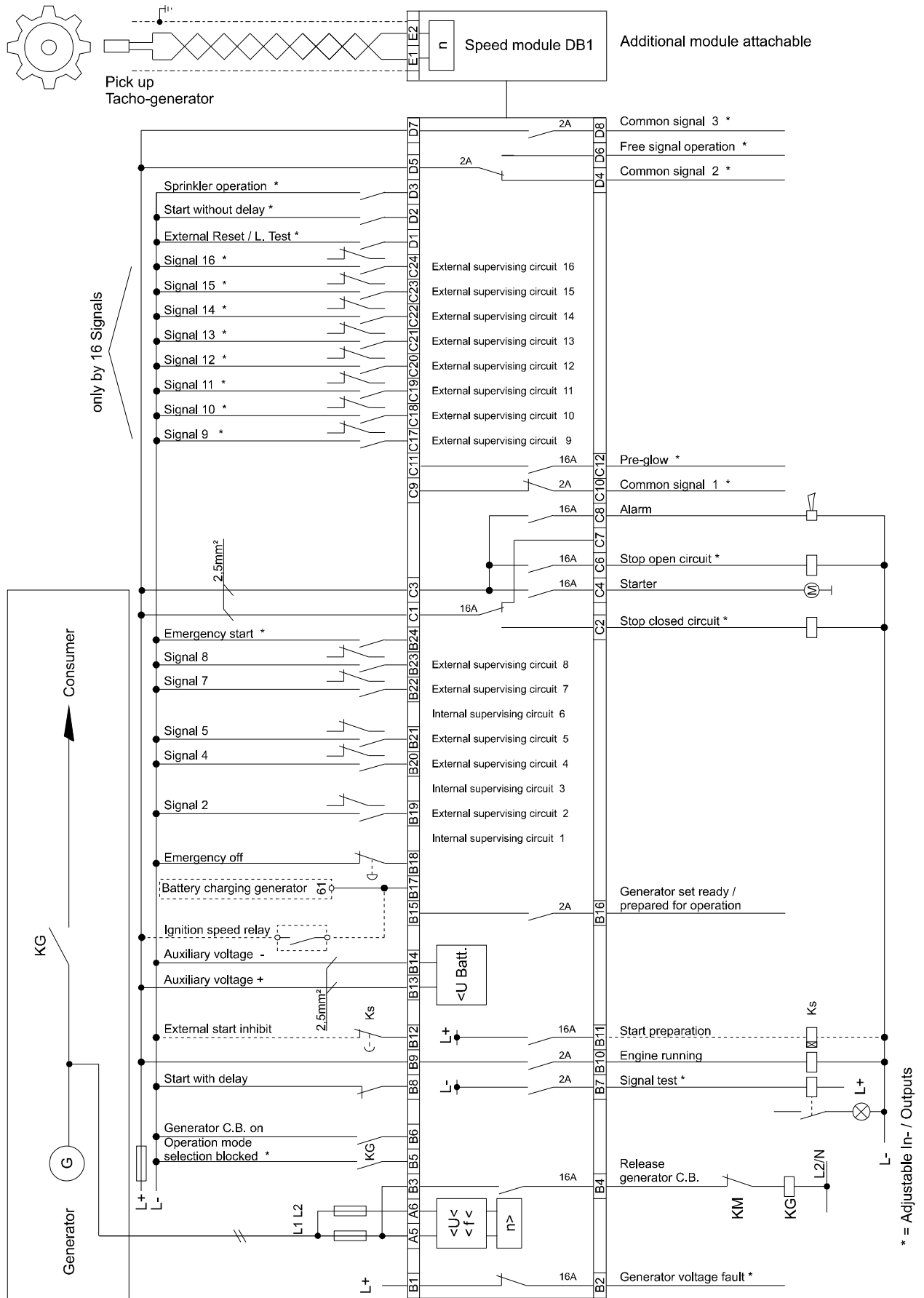

Figure 2.6: Connection diagram NC3-2-16 (for type NC3-2-8 inputs C17 - C24 do not apply)

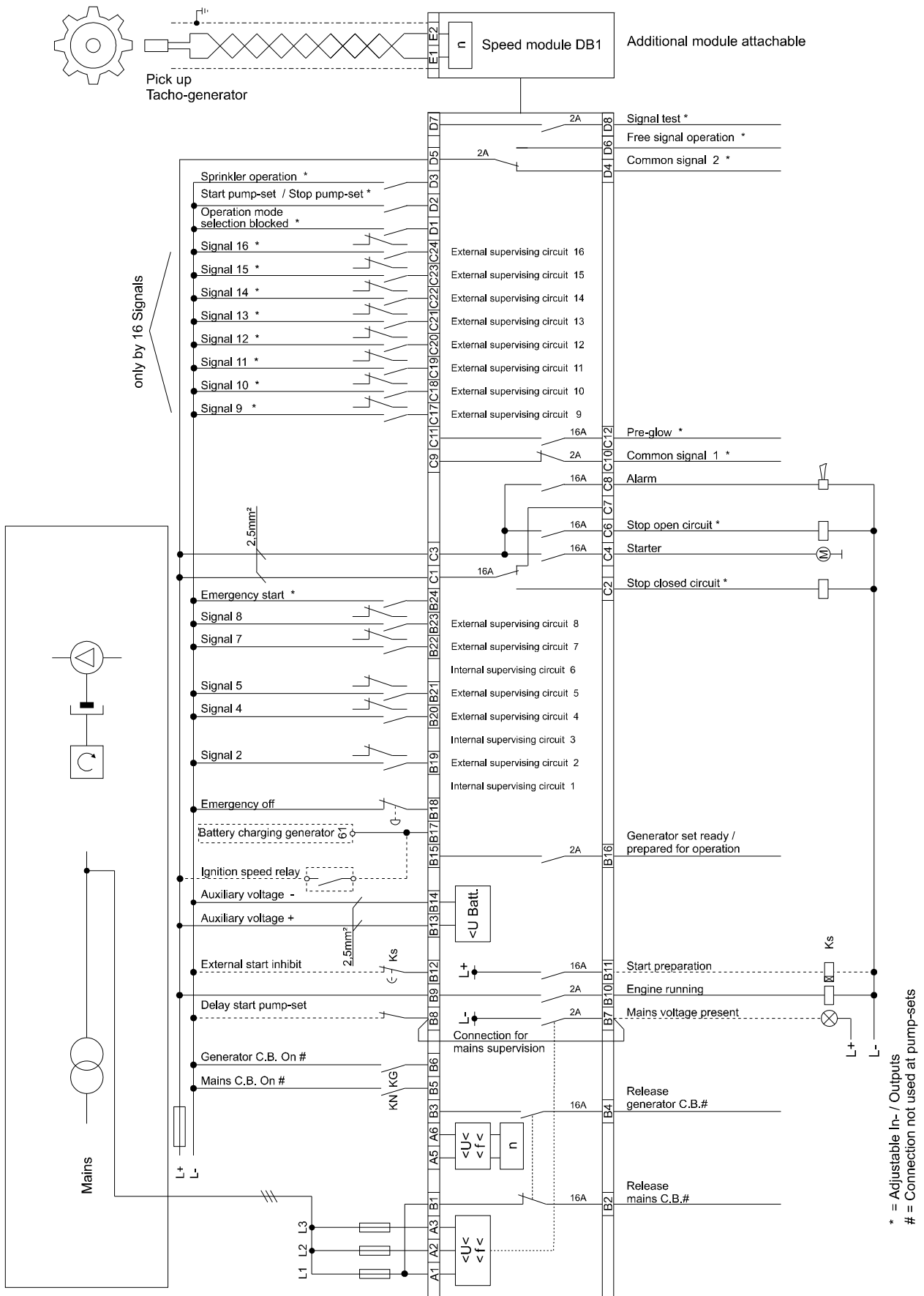

Figure 2.7: Connection diagram NC3-3-16

## 2.4 Description of inputs and outputs

In the following table inputs and outputs are briefly described with explanation of special functions.

Terminal	Description	Remarks
A1 - A3	NC3-1 and NC3-3: Input mains voltage L1, L2, L3 for 3-phase measuring of under/overvoltage, under/ overfrequency, detection of mains unbalance and phase loss. NC3-2: Not being used.	Max. 500 V/AC 50/60 Hz
A4	Not applicable	
A5, A6	NC3-1 und NC3-2: Generator voltage L1, L2 for single-phase measuring of under/overvoltage, under/overfrequency as well as ignition speed and overspeed. Voltage range in compliance with adjusted mains voltage. NC3-3: Not being used for pump sets.	Max. 500 V/AC 50/60 Hz
B1, B2	NC3-1 and NC3-3: Output for mains CB control. Internally used as potential-free NC contact, i.e. at aux. voltage failure the mains CB is closed. Control of mains reconnection failure in conjunction with input B5. NC3-2: Output for indicating a generator voltage failure, potential free NC contact.	Max. 16 A
B3, B4	Output for generator CB control. Internally used as potential-free NO contact.	Max. 16 A
B5	Input for checking the mains CB status. Evaluation of failures during switching back to the mains. Software parameter setting for open circuit/closed circuit principle.	L- (battery)
B6	NC3-1 and NC3-2: Input for checking the generator CB status. NC3-3: Not being used for pump sets. Software parameter setting for open circuit/closed circuit principle.	L- (battery)
B7	NC3-1: Output for mains supervision/mains failure detection. Aux. contact is closed when mains voltage available. NC3-2: Output for signal test of external operating components.	Max. 2 A
B8	NC3-1: Input for initiation of AMF operation and auto CB control. Function of this input is time delayed to avoid that the genset is started due to a short-term voltage drop. The start delay can be adjusted by the parameter setting software. NC3-2: Input for a delayed start. For an undelayed start input D2 applies. If no start delay is needed, L- has permanently to be applied to this input. NC3-3: Input for initiation of AMF operation. The start delay can be adjusted by the parameter setting software.	L- (battery)
B9, B10	Output for the potential-free NO contact for signal "Engine Running". Evaluation of the dynamo starting threshold value, or signal of an external speed relay, ignition speed threshold value and generator undervoltage switching point.	Max. 16 A

Terminal	Description	Remarks
B11	Output for start preparation. Control of, for instant, prelubrication pumps and jalousies. (See chapter Start Preparation/Start Blocking)	Max. 16 A L+ (battery)
B12	Input for start blocking. A start (energizing of starter relay C4) is prevented for the time L- is applied to this input (see chapter Start Preparation/Start Blocking) When L- is connected, a running genset is stopped.	L- (battery)
B13, B14	Aux.voltage L+ (battery) at B13, L- (battery) at B14. Measuring input for the 3-stage battery undervoltage supervision.	L+/L- (battery) 8 - 35V/DC/7.5W
B15, B16	Output for signal "Genset Ready for Operation". Potential-free NO contact which is closed in mode AUTOMATIC, unless a shut-down signal is given. Status signal for a master control system.	Max. 2 A
B17	Input for speed detection via dynamo threshold voltage or for external signal of a speed relay. At the same time output for dynamo additional excitation. Failure detection of speed impulse transmitter.	0 - 40 V/DC L+ (battery)
B18	Input for EMERGENCY STOP command (closed-circuit principle). See chapter 6.1 „EMERGENCY STOP“.	L- (battery)
B19 B20 B21 B22 B23	<p>Fault signal 2 (shut-down, delayed supervision, adjustable)            Fault signal 3 (intern.signal processing, shut-down, adjustable)            Fault signal 4 (shut-down, adjustable)            Fault signal 5 (shut-down with recooling, adjustable)            Fault signal 6 (intern.signal processing, warning, adjustable)            Fault signal 7 (warning, codable by DIP switch)            Fault signal 8 (indicating, codable by DIP switch/change of operational mode is blocked)</p> <p><b>Note:</b> When coding to open circuit principle, L- (battery) has to be applied at inputs in order to enable signalling. If the supervision circuits are coded for closed circuit principle, the signal circuit (L-) has to be disconnected to make fault signalling possible. (Setting only possible by software).</p>	<p>L- (battery)            CS1            CS1            CS1            CS1            CS2            CS1</p> <p>CS = common-signal</p>
B24	Input for emergency start of a genset by means of air pressure starter. After initialization, the automatic controller switches to mode MANUAL (see chapter 5.5).	L- (battery)
C1, C2	Output (Setting only possible by software) for ignition ON or speed regulator ON or connection of the operating magnet (shut-down, closed circuit principle). Potential-free NO contact closes at start demand.	Max. 16 A Output matrix
C3, C4	L+ (battery) at C3, internal NO contact provides start signal to output C4 during the start procedure. To be connected to starter terminal 50. <b>Note:</b> For control of the starter an external aux.relay is recommended.	Max. 16 A
C3, C6	C3 at L+ (battery). Output for stop command in open circuit connection (latching 10 s). NO contact switches L+ to output C6. <b>Note:</b> This contact must not be used in safety critical circuits where fail-safe contacts must be used only.	Max. 16 A Output matrix
C3, C8	L+ (battery) at C3, output C8 to be connected to horn or to be used as common alarm. After 5 minutes the output is de-activated automatically (adjustable).	Max. 16 A
C9, C10	Potential- free NC contact for common alarm 1. Internal alarm relay in closed circuit principle. Can also be used for self- test and alarm "Aux voltage failure"	Max. 2 A Output matrix
C11, C12	Output for potential- free NO contact. Intended for pre- glowing. (Default setting)	Max. 16 A Output matrix

Terminal	Description	Remarks
C17	Fault signal 9 (indicating, adjustable)	L- (battery)
C18	Fault signal 10 (warning, adjustable)	CS1
C19	Fault signal 11 (shut-down with recooling, adjustable)	CS1
C20	Fault signal 12 (shut-down, adjustable)	CS1
C21	Fault signal 13 (indicating, adjustable)	
C22	Fault signal 14 (warning, adjustable)	CS1
C23	Fault signal 15 (shut-down with recooling, adjustable)	CS1
C24	Fault signal 16 (shut-down, adjustable)	CS1
	Note: When coding with open circuit, L- (battery) has to be applied at inputs.	CS = common-signal Input matrix
D1	NC3-1: Input for function "Parallel Operation/Mains CB Control" (see chapter 7.3) NC3-2: Input for external "Reset" and "Lamp Test" NC3-3: Blocking of operational mode selection	L- (battery) Funktionsmatrix
D2	NC3-1: Input for function "Start / Generator CB Control" (see chapter 7.3) NC3-2 and NC3-3: Input for undelayed start (L- = Start/L+ = Stop)	L- (battery) Function matrix
D3	Input for Sprinkler operation (see chapter 7.4)	L- (battery)
D4, D5, D6	Potential-free changeover contact for common alarm 2. Internal alarm relay in closed circuit principle. Can also be used for self-test and alarm "Aux. Voltage Failure".	Max. 2 A Output matrix
D7, D8	NC3-1: Potential-free NO contact for function "Genset in Operation - Mains CB Release" Indicates genset. operation when the consumers are supplied by the mains (e.g. during no-load test). NC3-2: Potential-free NO contact for common alarm 3. Internal alarm relay in closed circuit principle. Can also be used for self-test and alarm "Aux. Voltage Failure". NC3-3: Potential-free NO contact for signal test of external operating components.	Max. 2 A Output matrix
E1, E2	Measuring inputs for speed impulse transmitter signal from pickup or dynamo	4 - 90 V/AC 1 - 10 kHz

Klemme	Funktionsbeschreibung	Bemerkung
F1	External control input for the button „Mains C.B. Off“ (only at NC3-1-8-P und NC3-1-16-P)	Potential free NO contact
F2	External control input for the button „Mains C.B. On“ (only at NC3-1-8-P und NC3-1-16-P)	Potential free NO contact
F3	External control input for the button „Generator C.B. Off“ (only at NC3-1-8-P und NC3-1-16-P)	Potential free NO contact
F4	External control input for the button „Generator C.B. On“ (only at NC3-1-8-P und NC3-1-16-P)	Potential free NO contact
F5	External control input for the button „Test“ (only at NC3-1-8-P und NC3-1-16-P)	Potential free NO contact
F6	External control input for the button Taste „Stop“ (only at NC3-1-8-P und NC3-1-16-P)	Potential free NO contact
F7	External control input for the button „Start“ (only at NC3-1-8-P und NC3-1-16-P)	Potential free NO contact
F8	External control input for the button „Horn“ (only at NC3-1-8-P und NC3-1-16-P)	Potential free NO contact
F9	External control input for the button „0“ (only at NC3-1-8-P und NC3-1-16-P)	Potential free NO contact
F10	External control input for the button „Automatic“ (only at NC3-1-8-P und NC3-1-16-P)	Potential free NO contact
F11	External control input for the button „Manual“ (only at NC3-1-8-P und NC3-1-16-P)	Potential free NO contact
F12	External control input for the button „Reset/L Test“ (only at NC3-1-8-P und NC3-1-16-P)	Potential free NO contact
F13, F14	Common return wire, reference potential for the external button control inputs. These terminals are <u>not</u> electrically connected with L- (Battery).	Reference potential

Table 2.3: Inputs and outputs

## 2.5 Configuration of connection terminals and coding switches

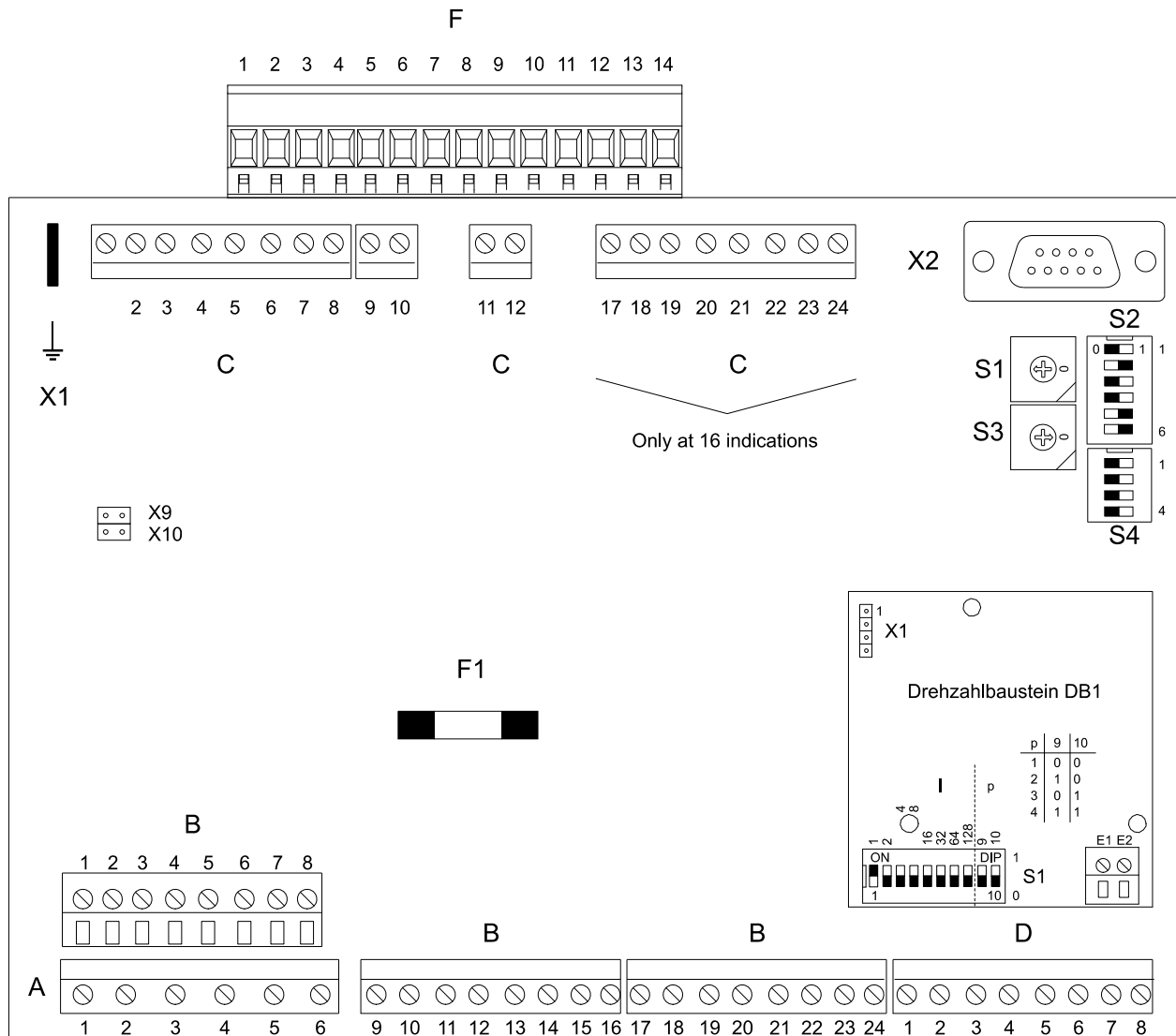

Figure 2.8: Rear view of NC3

- F1 - Fuse (250V/4A, quick)
- S1 - Selector switch for mains voltage
- S3 - Selector switch for parameters and delay times
- S2 - Coding switch for supervision circuits 7 and 8
- S4 - Battery 12V/24V, Pb/NiCd, frequency, open/closed circuit for "Emergency-STOP"
- X1 Earthing connection
- X2 - RS232-interface
- X9 - Additional dynamo excitation
- X10 - Additional dynamo excitation

The terminals F1 – F14 only exist at the types NC3-1-8-P and NC3-1-16-P!

For mounting or dismounting of the device, the terminal strip can be unplugged before.

### **3 Mains supervision**

The automatic controller *NC3* supervises mains voltage and frequency of three-phase LV and MV systems (inputs A1, A2, A3) and additionally detects voltage unbalance of three-phase systems.

The mains voltage supervision controls circuit breakers of mains and generator as well as the program flow for starting and stopping the genset. By switching off the mains CB, the consumers are protected against mains failures.

#### **3.1 Mains failure/emergency power operation (B7/B8)**

##### **NC3-1**

AMF operation as well as automatic CB control of single gensets are normally controlled by the internal mains supervision unit. For this purpose terminals B7 and B8 have to be bridged. If mains voltage and frequency are in the permissible range, the internal contact is closed and L- is applied to output B7 and input B8. AMF operation is initiated, when L- is disconnected from input B8.

If the internal mains supervision element is used, the internal contact opens in case of mains failure and the AMF operation is initiated; the consumers are now supplied by the genset.

After mains restoration, automatic changeover to mains supply is initiated only after elapse of the mains recovering time.

##### **NC3-2**

In multiple systems the NC3-2 also can be used for AMF operation, but with this controller CB control and especially interlocking between mains and generator CB has to be realized from external. In this case start of the genset can either be initiated undelayed by connecting input D2 or delayed by disconnecting input B8.

##### **NC3-3**

Like the NC3-1, this pump set controller has also a mains supervision element which initiates pump set operation at mains failure (B7/B8, see chapter 10)

## 3.2 Mains voltage supervision

### 3.2.1 Selection of the rated mains voltage

Switch S1 for selecting the rated mains voltage is at the rear of the **NC3**. By using this switch sixteen different combinations of rated voltages/switching points with different undervoltage and overvoltage switching points can be chosen. Default setting of the mains voltage is 400 V (switch position 9).

Switch position	Mains voltage [V]	U<	U>	Switching point [%]
0	100	94	110	- 6 / + 10
1	110	103	121	- 6 / + 10
2	220	207	242	- 6 / + 10
3	100	90	115	- 10 / + 15
4	110	99	127	- 10 / + 15
5	220	198	253	- 10 / + 15
6	100	85	120	- 15 / + 20
7*	220	187	264	- 15 / + 20
8	380	357	418	- 6 / + 10
9	400	376	440	- 6 / + 10
A	415	390	457	- 6 / + 10
B	380	342	437	- 10 / + 15
C	400	360	460	- 10 / + 15
D	415	373	478	- 10 / + 15
E	400	340	480	- 15 / + 20
F*	460	432	506	- 6 / + 10

Table 3.1: Rated voltages possible to be selected by DIP switch S1

 Default setting

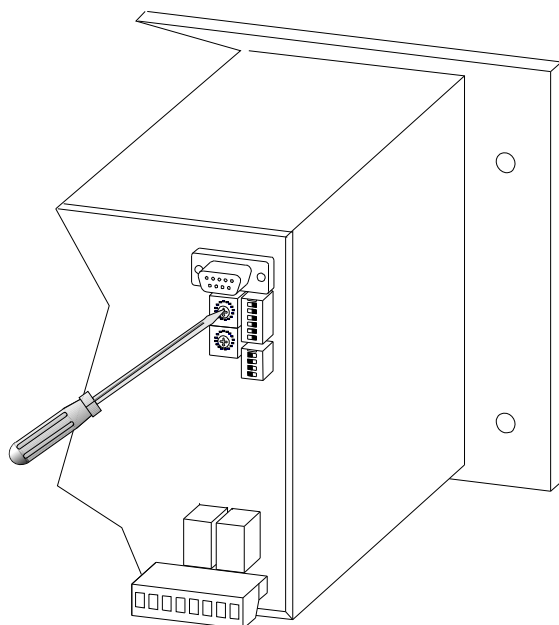

Figure 3.1: Setting of rated voltages by switch S1

### 3.2.2 Overvoltage and undervoltage switching points of the mains voltage supervision

Tolerance of the mains undervoltage switching point is -6% and of the mains overvoltage switching point +10% from the rated value of the mains voltage (see Table 3.1). Mains overvoltage and undervoltage are regarded as mains failure, i.e. an AMF operation is initiated in operational mode AUTOMATIC.

In cases where different rated voltages or undervoltage/overvoltage switching points are requested than shown in the table, the initially set values can be changed by the parameter setting software in switch positions 7 and F. The new values are then saved in a nonvolatile EEPROM memory and are still maintained, even if the switch position of S1 is changed. The mains supervision is provided with an additional time circuit (time delay "Mains voltage present", default setting  $t_{mp} = 0.1s$ ) in order to make transient voltage spikes (mains voltage flicker) ineffective.

By this time circuit control of output B7 can be delayed and it is adjusted by the parameter setting software.

A voltage failure is indicated by the slowly flashing LED **11** (mains voltage).

### 3.2.3 Function of the mains voltage supervision

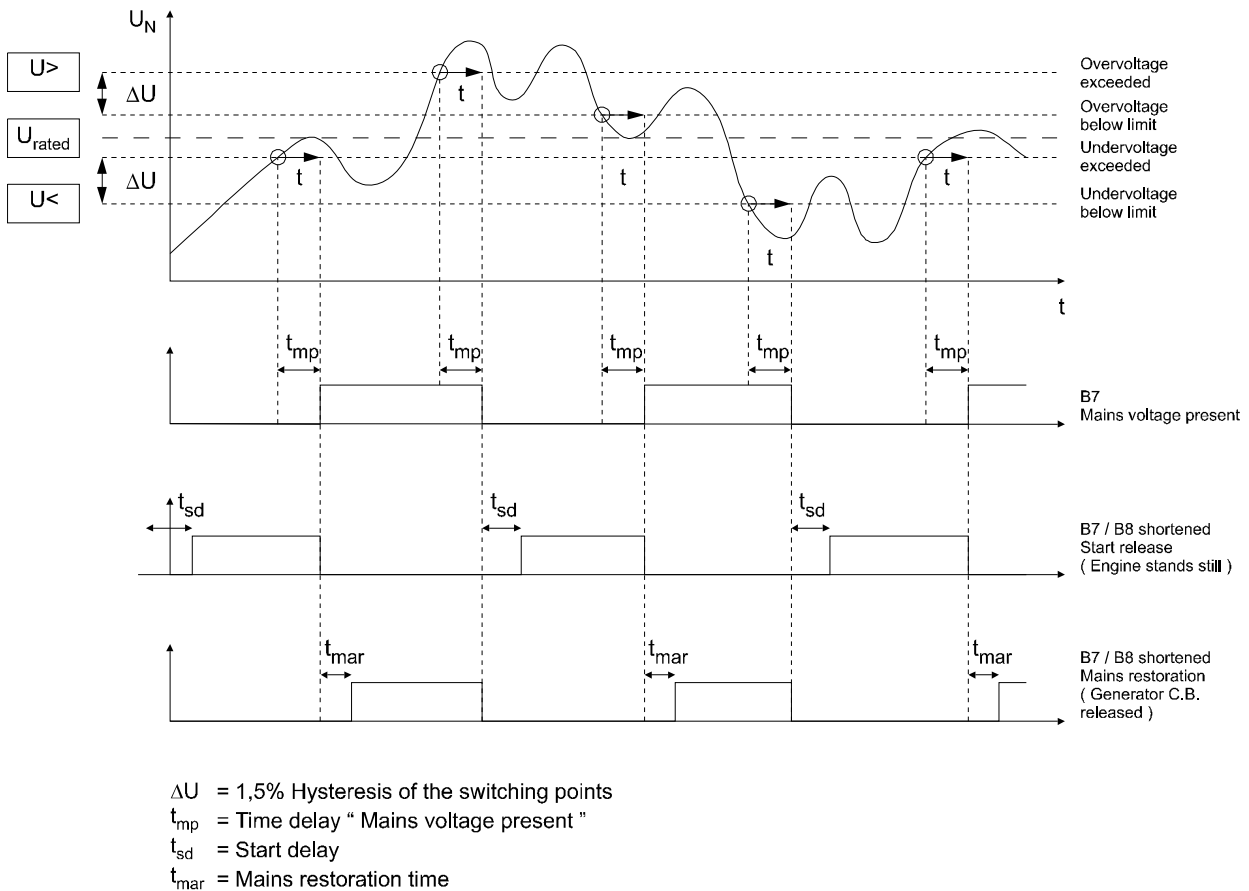

Figure 3.2: Function of the mains voltage supervision

### 3.3 Mains frequency supervision

#### 3.3.1 Selection of rated frequency

The rated frequency is set by coding switch S4, position 3.

Switch S4 Position	Function	Position	
		0	1
3	Rated Freq.	50 Hz	60 Hz

Table 3.2: Frequency settings

Default setting

#### 3.3.2 Over- and underfrequency switching points of the mains frequency supervision

For controlling the mains frequency, the NC3 is provided with a frequency supervision. This supervision can be deactivated via the parameter setting software.

When a frequency failure occurs, the mains CB is switched off by the frequency supervision (default setting). This function of the frequency supervision can be changed per parameter setting software to the effect that a mains frequency failure initiates AMF operation, as this is the case with mains voltage failures. It can also be determined whether underfrequency, overfrequency or both shall result in AMF operation.

A mains frequency failure is indicated by the slowly flashing LED **11** (mains voltage).

### 3.3.3 Function of the mains frequency supervision

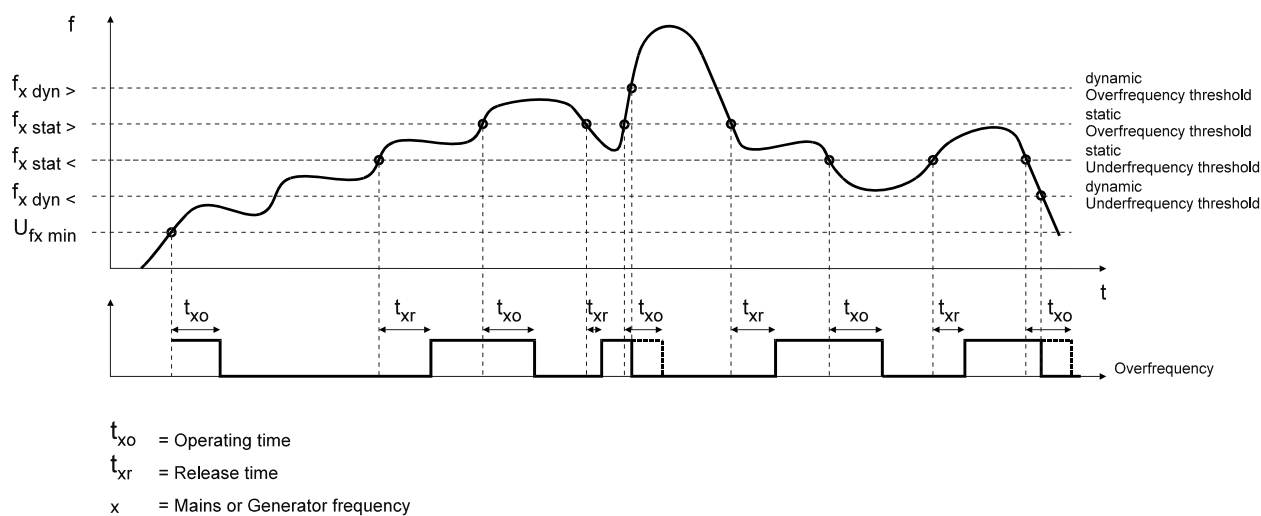

Figure 3.3: Function of the mains frequency supervision

### 3.3.4 Minimal input voltage for evaluating the frequency

The minimal input voltage for evaluating the frequency is adjustable by parameter setting software (default setting = 10%), but the frequency supervision does not operate if the input voltage is below 6 V.

### 3.3.5 Static and dynamic frequency deviation

For the underfrequency element and overfrequency element, the mains frequency supervision has two switching points each. On frequency deviations  $>\pm 5\%$  (static frequency deviation  $f_{m\ stat <}$  and  $f_{m\ stat >}$ ) the operating time  $t_{mo} = 5$  s.

Frequency deviations of more than  $\pm 10\%$  (dynamic frequency deviation  $f_{m\ dyn <}$  and  $f_{m\ dyn >}$ ) lead to immediate activation of the frequency supervision.

The frequency is regarded to be in the permissible range again if it does not deviate more than  $\pm 5\%$  from the rated frequency after elapse of the release time ( $t_{mr} = 1$  s) (see Figure 3.3).

$f_{rated}$ [Hz]	$f_{m\ stat <}$	$f_{m\ stat >}$	$f_{m\ dyn <}$	$f_{m\ dyn >}$
50	47.5	52.5	45.0	55.0
60	57.0	63	54.0	66.0
Operat. time	$t_{mo} = 5$ s	$t_{mo} = 5$ s	direct	direct

Table 3.3: Switching points of the mains frequency supervision

Default setting

### 3.4 Supervision of mains voltage unbalance

This supervision element compares the three phase conductor voltages of the mains and is activated if the lowest phase conductor voltage differs more than 25% from the highest value (pickup value). The mains unbalance is in a tolerable range if the difference is not more than 12% (disengaging value). Any mains unbalance not within the permissible range is regarded as mains failure and is indicated by the slowly flashing LED **11** (mains voltage).

The supervision of mains voltage unbalance is switched on and off via the parameter setting software. The pickup value  $A_{sym\ p}$  can be adjusted in a range between 4 - 30% and the drop-off value  $A_{sym\ d}$  in a range between 3 - 29%.

### 3.5 Switching-on delay of the mains CB

During changing over the consumers from mains supply to generator supply or vice versa, the switching off time of the CBs is of great importance. To prevent unintended overlapping of the CBs (asynchronous switching in parallel), the **NC3** is provided with an adjustable switching-on delay ( $t_{sm} = 0,8$  s) for the CBs.

### 3.6 Circuit breaker supervision during mains reconnection

When the mains is recovering in AMF operation, the consumers are automatically reconnected to the mains in operational mode AUTOMATIC. In order to ensure that the mains is stable at the time of changing over, the *Mains Recovering Time* has to elapse first before consumers are reconnected.

If there is anything wrong with the automatic change-over procedure, meaning the **NC3** has no duly check-back signal of the mains CB after 10 s (after elapse of the mains reconnection time), alarm "Mains Reconnection Failure" is given. This failure is indicated by alternately quick flashing LED ⑦ (Mains CB) and LED ⑪ (Mains Voltage Available) and additionally signalled by the output contact C9/C10 (common alarm 1), the RESET/L.TEST LED ⑩ and LED HORN ⑨. This fault can also be assigned to common alarms 2 and 3.

As soon a failure in mains reconnection becomes apparent, consumers are switched back to the running genset because power supply of consumers has first priority (e.g. hospitals).

By pressing push-button RESET/L.TEST alarms can be cancelled and a new mains reconnection attempt be started.

Supervision of the mains recovery can be deactivated by the parameter setting software.

### 3.7 Synchronization supervision (NC3-1)

For parallel operation with the mains an additional external synchronizing unit is needed. In the **NC3** a synchronization supervision is integrated, checking whether the initiated synchronization procedure is duly completed.

Together with the parallel operation command (input D1), the internal time circuit "Synchronization Supervision" is started ( $t_{sy} = 120$  s). The completed synchronization procedure is detected by the **NC3** through check-back signals of mains and generator CBs.

If the **NC3** does not receive these signals within time  $t_{sy}$ , this fault is indicated by simultaneously flashing LEDs for mains CB and generator CB; the common alarm is then activated.

### 3.8 Switching over delay in test mode

As described in chapter 2.1, the mains CB release can automatically be disabled and the generator CB be switched on for load test purposes by pressing the generator CB push-button. The switching over delay is  $t_{st} = 0.5$  s.

## 4 Generator supervision

The generator voltage supervision element protects the connected consumers against inadmissible generator voltage values or frequency values as well as supervises the speed of the genset. In AMF operation this element controls closing of the generator CB. For measuring purposes two phases are used (L1, L2).

### 4.1 Generator voltage supervision

#### 4.1.1 Rated generator voltage

The rated generator voltage cannot be selected separately, because it depends on the rated value of the mains voltage according to chapter 3.2.1. Default setting of the rated voltage is 400 V.

When using the **NC3** in medium voltage systems where, for instance, the mains voltage is measured by voltage transformers (e.g. 3 x 100 V) and the generator voltage is measured at the low voltage side (L1/L2 = 400 V), it is possible to adjust different rated voltages per parameter setting software at switch positions 7 and F.

Switch-position	Generator-voltage [V]	U<	U>	Switching point [%]
0	100	85	110	-15 / +10%
1	110	93	121	-15 / +10%
2	220	187	242	-15 / +10%
3	100	85	110	-15 / +10%
4	110	93	121	-15 / +10%
5	220	187	242	-15 / +10%
6	100	85	110	-15 / +10%
7*	220	187	242	-15 / +10%
8	380	323	418	-15 / +10%
9	400	340	440	-15 / +10%
A	415	352	457	-15 / +10%
B	380	323	418	-15 / +10%
C	400	340	440	-15 / +10%
D	415	352	457	-15 / +10%
E	400	340	440	-15 / +10%
F*	460	391	506	-15 / +10%

Table 4.1: Rated voltages selectable by switch S1

Default setting

Overvoltage and undervoltage switching points of the generator voltage supervision element are equal in all switch positions. In positions 7 and F the switching points can also be changed per parameter setting software.

During generator overvoltage or undervoltage conditions the generator CB release is disabled, but the genset keeps on running (see chapter 4.4).

### 4.1.2 Function of the generator voltage supervision

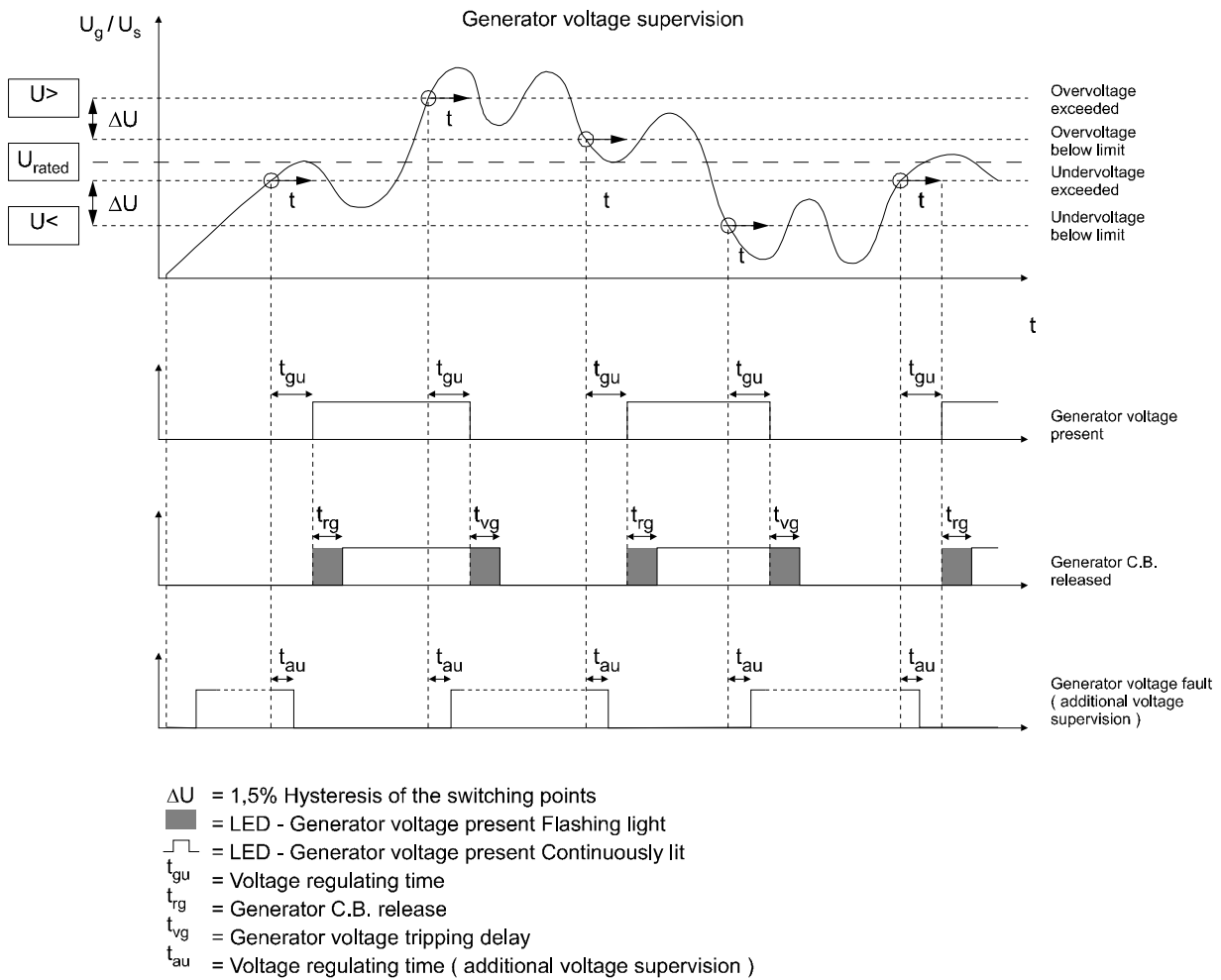

Figure 4.1: Function of the generator voltage supervision

### 4.1.3 Voltage regulating time

The generator voltage LED ⑫ is only activated and a voltage fault internally processed if overvoltage or undervoltage conditions prevail during voltage recovering time  $t_{gu}$ . By this function wrong indications and malfunctions due to short-term voltages spikes and voltage dips are prevented.

## 4.2 Generator frequency supervision

### 4.2.1 Rated generator frequency

The rated generator frequency is conditional on the set rated mains frequency.

### 4.2.2 Function of the generator frequency supervision

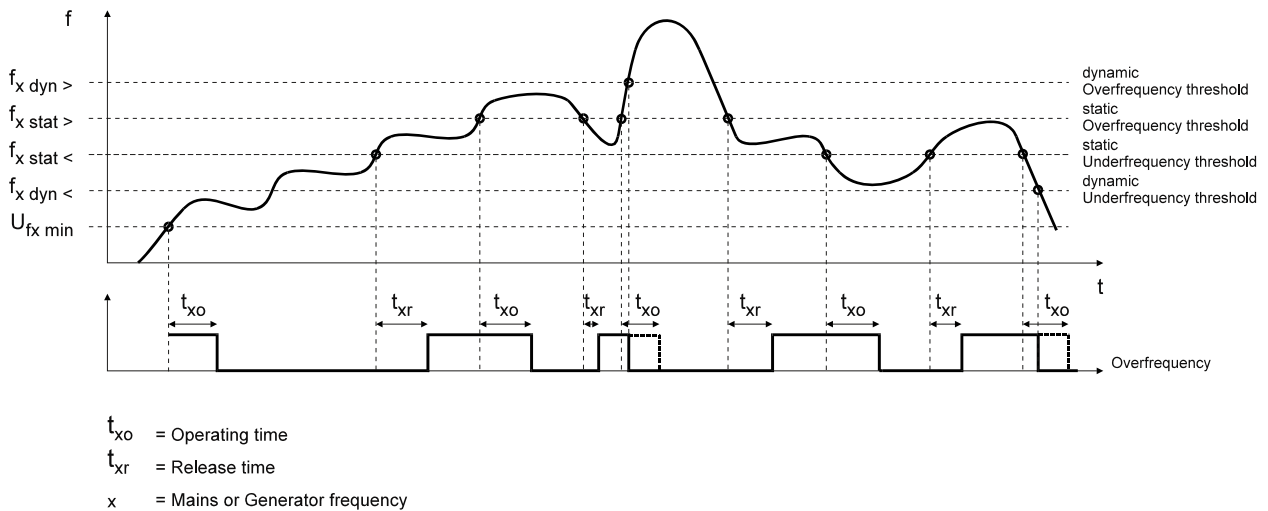

Figure 4.2: Functions of the generator frequency supervision

### 4.2.3 Other settings of the generator frequency supervision

Deactivation of the generator frequency supervision is only possible per parameter setting software NC3-Soft.

All other settings, such as min. voltage for evaluation of frequency, static and dynamic frequency deviations as well as activation and de-activation time which are in compliance with those of the mains frequency supervision element, can be adjusted by means of the parameter setting software.

The generator frequency supervision element either detects the frequency from the generator voltage or via the connected speed module DB1. Where voltages with high harmonic content are concerned, frequency measuring by the DB1 has proved to be far more exact, because it is not the generator voltage which is evaluated, but the signal from an external speed sensor. The optionally speed module DB1 has to be switched on by the parameter setting software.

$f_{rated}$ [Hz]	$f_{g stat <}$	$f_{g stat >}$	$f_{g dyn <}$	$f_{g dyn >}$
50	47,5	52,5	45,0	55,0
60	57,0	63	54,0	66,0
Oper. time	$t_{go} = 5$ s	$t_{go} = 5$ s	direct	direct

Table 4.2: Set switching points of the generator frequency supervision

Default setting

According to GL (German Lloyd) regulations the permissible continuous frequency deviation is maximal  $\pm 5\%$ .

On frequency deviations  $> \pm 5\%$  (static frequency deviation  $f_{g stat <}$ , and  $f_{g stat >}$ ) the operating time  $t_{go} = 5$  s. Frequency deviations of more than  $\pm 10\%$  (dynamic frequency deviation  $f_{g dyn <}$ , and  $f_{g dyn >}$ ) lead to immediate activation of the frequency supervision.

The frequency is regarded to be in the permissible range again if it does not deviate more than  $\pm 5\%$  from the rated frequency after elapse of the release time ( $t_{gr} = 1$  s) (see Figure 4.2).

Incorrect frequency is indicated by fast flashing "Generator Voltage" LED <U> (12)

During underfrequency the generator CB release can be disabled/delayed. This function and the corresponding time circuit are set by the parameter setting software (operating time  $t_{go}$ ). Despite of underfrequency the genset remains still in operation. Generator overfrequency conditions are indicated only (LED <U> (12)).

### **4.3 Switching-on delay of the generator CB**

To prevent unintended overlapping of the CBs (asynchronous switching in parallel), when the consumers are switched over from generator supply to mains supply or vice versa, the NC3 is provided with an adjustable switching-on delay ( $t_{sg} = 0,8 \text{ s}$ ) for the CBs.

#### 4.4 Additional generator voltage supervision

The NC3 is provided with an additional generator voltage supervision element which not only supervises the generator voltage but the generator frequency as well. Unlike a normal voltage supervision unit, where generator voltage failures are only indicated, this separate voltage supervision protects the consumers connected by directly switching them off and shutting down the genset in case of failure.

Generator voltage and generator frequency (default setting) are both supervised by the separate voltage supervision. Voltage and frequency supervision can be deactivated by the parameter setting software.

The shutting down function of the voltage supervision can also be blocked by the parameter setting software. In such a case an output can be allocated to a potential fault and if required, interlinked with an alarm input.

A generator voltage failure is indicated by fast flashing of the "Generator Voltage" LED <U> (12) and can be reset by push-button RESET/L.TEST after the genset has stopped.

Switch-position	Generator-voltage [V]	U<	U>	Switching point [%]
0	100	85	120	-15 / +20%
1	110	93.5	132	-15 / +20%
2	220	187	264	-15 / +20%
3	100	85	120	-15 / +20%
4	110	93.5	132	-15 / +20%
5	220	187	264	-15 / +20%
6	100	85	120	-15 / +20%
7*	220	187	264	-15 / +20%
8	380	323	456	-15 / +20%
9	400	340	479	-15 / +20%
A	415	352.7	498	-15 / +20%
B	380	323	456	-15 / +20%
C	400	340	479	-15 / +20%
D	415	352.7	498	-15 / +20%
E	400	340	479	-15 / +20%
F*	460	391	552	-15 / +20%

Table 4.3: Switching points of the separate voltage supervision

Default setting

Before the genset is directly shut down and the generator voltage LED (12) activated as result of a voltage failure, overvoltage or undervoltage conditions must prevail during voltage regulating time  $t_{av}$ .

The frequency switching points of the separate generator voltage supervision have a tolerance of  $\pm 15\%$ .

$f_{rated}$ [Hz]	$f_{a<}$	$f_{a>}$
50	42,5	57,5
60	51,0	69,0
Operating time	$t_{ao} = 5$ s	$t_{ao} = 5$ s
Release time	$t_{ar} = 1$ s	$t_{ar} = 1$ s

Table 4.4: Pre-set switching points of the separate generator voltage supervision

Default setting

The frequency is ascertained either from the generator voltage (default setting) or via speed module DB1.

#### Note:

If a genset is operated without excitation of the generator, e.g. during no-load test of the prime mover, the voltage supervision as well as the frequency supervision of the separate generator voltage supervision have to be deactivated because otherwise the genset is stopped after elapse of both the voltage regulating time ( 5.1 s) and the operating time (5s).

## 5 Genset control

In this chapter all parameters for adjusting the **NC3** to the wide range of diesel and gas gensets are explained.

The setting possibilities at the **NC3** are very wide ranging and so there is no extensive programming involved as this is the case e.g. with PLCs.

### 5.1 Aux. Voltage supply

Due to the wide operational range of the **NC3** (from 8 - 35 V/DC), this unit can be fed directly from the starter battery (12 V or 24 V). This not only applies to conditions like start of the genset when the stress on the battery is considerable, but also at increased output voltage of the battery charger, e.g. when boost charging is activated or the battery is disconnected. When battery voltage is applied (terminals B13/B14), this initialization process is indicated by successive short flashing of some LEDs. After the initialization process is completed, the **NC3** changes to operational mode "0" and thereafter the desired mode can be selected.

#### Note:

For generator protection a microfuse (250V/4A/quick) is provided underneath the cover at the rear.

#### 5.1.1 Aux. Voltage failure

After failure of the aux. voltage, all cleared alarms are reset. When the aux. voltage is restored, all existing alarms of immediate shut-down function appear as first up indication (fast flashing).

Basically it has to be distinguished between the following two cases:

#### Short-term failures of the auxiliary voltage (up to about 2s)

Operational mode AUTOMATIC as well as the actual status of CBs remain stored in AUTOMATIC mode. From operational modes TEST and MANUAL it is then changed to mode "0". After the aux. voltage is restored again, the mains CB is closed and the generator CB opened, provided the mains CB or generator CB was in operation before the failure. The mains CB, however, only closes if the generator CB has opened at the instant of aux. voltage recovery and that CB status has been duly confirmed.

#### Long-term failures of the aux. voltage (>2s)

After the aux. voltage was not available for a longer period, the **NC3** always changes to operational mode "0", irrespective of the mode selected before the interruption of aux. voltage.

When the aux. voltage is restored again, the mains CB is closed and the generator CB opened.

The EEPROM memory ensures that an aux. voltage failure does not effect the set parameters, they will not be changed.

### 5.2 Definition of the battery type and rated battery voltage

DIP switch S4 is used for defining the battery type and rated battery voltage.

Swich S4 No.	Designation	Position	
		0	1
1	Battery type	Pb	NiCd
2	Batt.- voltage	24 V	12 V

Table 5.1: Battery voltage and battery voltage switching points

Default setting

#### 5.2.1 Internal supervision of the battery voltage (B13/B14)

A three-stage supervision for battery undervoltage and single stage supervision for battery overvoltage are integrated in the **NC3**, assigned to supervision circuit 6. The input voltage ranges from 8 - 35V/DC, but below 8V neither supervision nor indication are possible.

This warning coded supervision circuit operates with time delay. A battery voltage failure is indicated via output D4/D5 (common alarm 2) and at LED of the 6<sup>th</sup>. Supervision circuit.

### 5.2.2 Setting of the battery undervoltage switching points

Switching points of the first undervoltage element can be adjusted, whereas those of the second and third element are calculated from the first one. All switching points are in accordance with DIN 6380-13.

Switching point  $U_{b<}$  of the first battery undervoltage element should be based on the total voltage of the battery cells. If the battery data sheets do not give clear information on the values, the battery manufacturer should be contacted.

Type	Rated voltage	step [V]		
		$U_{b<}$	$U_{b<<}$	$U_{b<<<}$
Pb	24 V	25.2	22.7	20.2
NiCd	24 V	26.0	23.4	20.8
Pb	12 V	12.6	11.3	10.1
NiCd	12 V	13.0	11.7	10.4
Operating delay		$t_{b<}$	$t_{b<<}$	$t_{b<<<}$
		900 s	450 s	56 s

Table 5.2: Undervoltage switching points and operating time delay of the battery voltage supervision

Default setting

The time circuits for operating delay can be set for each undervoltage element separately.

### 5.2.3 Setting of the battery overvoltage protection

If a defective battery is charged (IU characteristic), the result is overloading of the battery and gas formation and this leads to voltage rise of the DC voltage supply. Damage of the consumers connected is prevented by the integrated battery overvoltage protection.

#### Note:

If the overvoltage supervision shall be used, it must be activated via the parameter setting software.

The following switching points are set at works, values of which are to be understood in percentage terms and they are based on the value of the first undervoltage element  $U_{b<}$ .

Type	$U_{b<}$	step	
		$U_{b>}[V]$	$U_{b>}[%]$
Pb	25,2	28,0	11
NiCd	26,0	31,2	20
Pb	12,6	14,0	11
NiCd	13,0	14,4	20
Operating delay $t_{b>}$		29 s	

Table 5.3: Battery undervoltage switching points

Default setting

Battery overvoltage is signalled the same way as battery undervoltage.

### 5.3 Start cycle

On start request, either by pressing push-button START in operational mode MANUAL, or due to mains failure in mode AUTOMATIC or TEST,

output B11 is activated and the start initiated after elapse of the start delay.

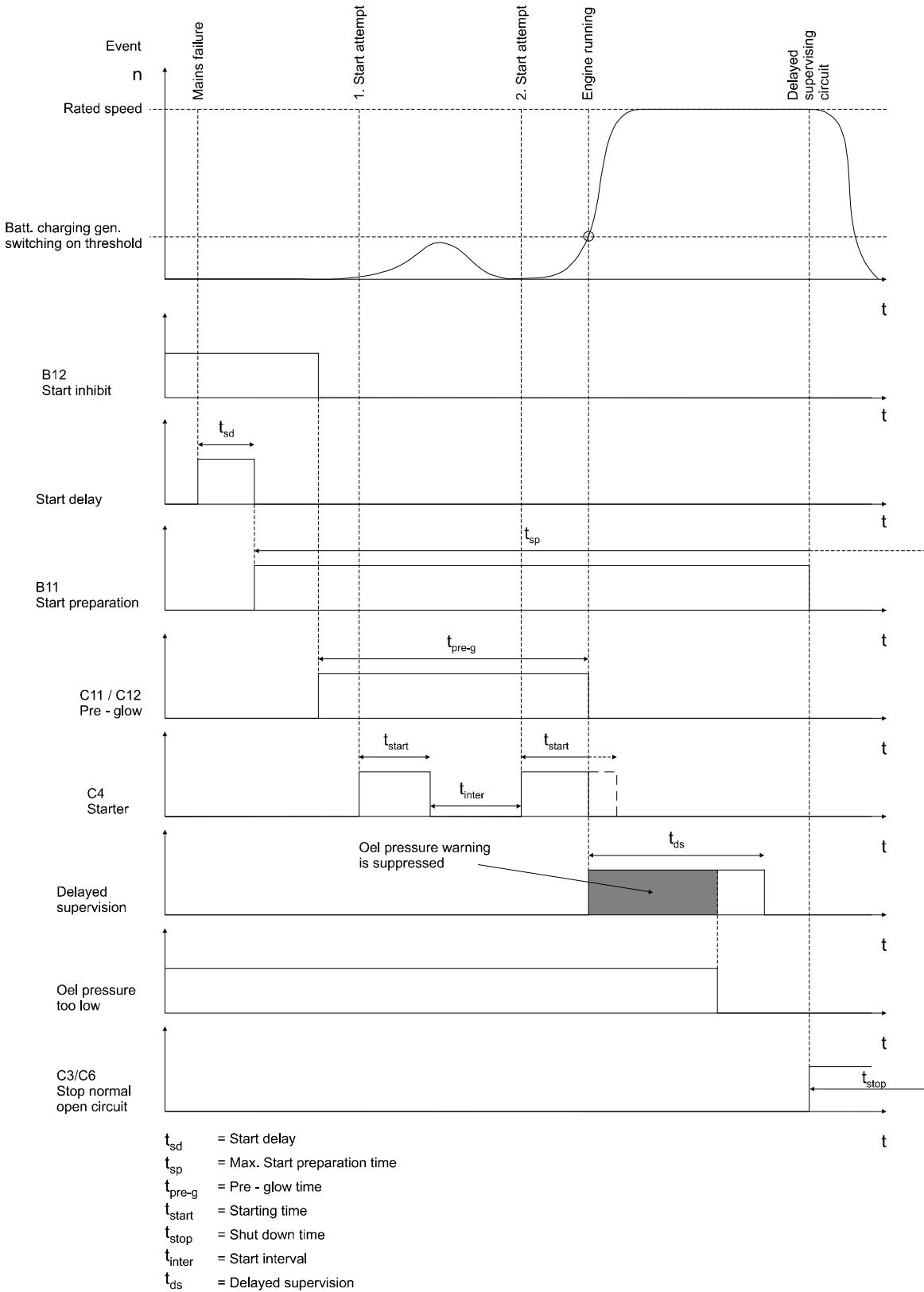

Figure 5.1: Start cycle

## 5.4 Start preparation / Start blocking

Prior to the starting procedure for some gensets certain preparations are necessary, e.g. switching on of pre-lubrication pumps or opening of jalousies. If this process should function automatically, the start has to be blocked for this time (output B12). Blocking of the start is indicated by slowly flashing LED ⑤. After the start delay time  $t_{sd}$  has elapsed, L+ is connected to output B11 see Figure 5.1. For control of the pre-lubrication pump or the jalousies for instance, an external aux. relay can be connected to this output. Check-back contacts (pressure supervision etc.) or limiting switch (jalousies) have to be interlinked as NC contacts parallel in the start blocking chain (B12). Only after the start blocking chain is opened, output C11/C12 (pre-glowing) is activated and the start relay at output C4 energized after pre-glowing time  $t_{pre-g}$  has elapsed. After a successful start, the time circuit "Delayed Supervision" ( $t_{ds}$ ) elapses. Any alarms which are delayed supervised, e.g. "Oil Pressure Too Low", are suppressed during this time ( $t_{ds}$ ). This, however, does not apply to direct shut-down alarms.

Some of the operating components for start preparation (electric motors and coils) are not designed for continuous operation and for their protection the max. start preparation time  $t_{sp}$  is limited to 120 s. This time can be changed per parameter setting software (time circuit "Maximal start preparation"). If the start is not completed by elapse of this time, "Start preparation failure" is signalled. This fault is indicated by quickly flashing LED ⑤. Remote indication of this fault is possible via one of the three common alarm relays and can be acknowledged by push-button RESET/L.TEST.

In case operating components are connected to output B11 for which a continuous signal is needed, the start preparation supervision can be deactivated per parameter setting software.

### Note:

If a start is blocked when the genset is in operation, stopping of the set is initiated instantly.

## 5.5 Emergency start B24

Many regulations, e.g. those of the German Lloyd, very often require two different starting methods for safety reasons. Besides starting by a battery operated starter, an alternative start by an air pressure starter (emergency start) must also be possible. If the starter battery fails (no aux. voltage), an emergency start by the air pressure starter is carried out without the **NC3**. When the aux. voltage arises the dynamo, the **NC3** normally changes to operational mode 0 (OFF) and the genset is stopped. During an emergency start, however, this function is not desired. So by energizing input B24 (see chapter 7.1) it is changed to mode MANUAL at aux. voltage recovery. The mains CB remains switched on (**NC3.1**), irrespectively whether mains voltage is available or not. After generator voltage is available, the generator CB can be switched on manually. The operational mode can only be changed when L- is disconnected from B24. The emergency start function is indicated by the quickly flashing LED MANUAL.

## 5.6 Dynamo and "Genset Running" indication (B17)

From the dynamo voltage the **NC3** receives the information whether the genset has started all right. A start is considered successful when the dynamo voltage reaches 75% of the battery voltage within the start-up time (10 s). As soon as this *switching-on threshold* (75%) is reached, the starter relay de-energizes (output C3/C4). In case this switching-on threshold is not reached before the starting time has elapsed and if there is no generator voltage available, a new start attempt follows. If during operation and with existing generator voltage the dynamo voltage drops below 50% of the battery voltage (*switching-off threshold*), this is considered as failure of the speed sensor i.e. defect of the dynamo or the V-belt. This is a warning kind of fault and has a start blocking effect at the same time, i.e. a running genset is not stopped. Start of the genset is only possible after the alarm has been reset.

### 5.6.1 Adjustment of the additional excitation

During the starting process of a genset, AC dynamos need an additional excitation and this excitation is provided by the **NC3**. Together with the start command, the battery voltage (L+) is connected to terminal B17 via resistor. Intensity of the additional excitation can be adapted to the different dynamo types at the rear of the **NC3** by means of coding plugs.

Coding-plug	Without coding plug	1 coding plug	2 coding plugs
X9 and X10	No add. excitation	Low add. excitation 120 Ω	High add. excitation 60 Ω

Table 5.4: Additional dynamo excitation X9 and X10

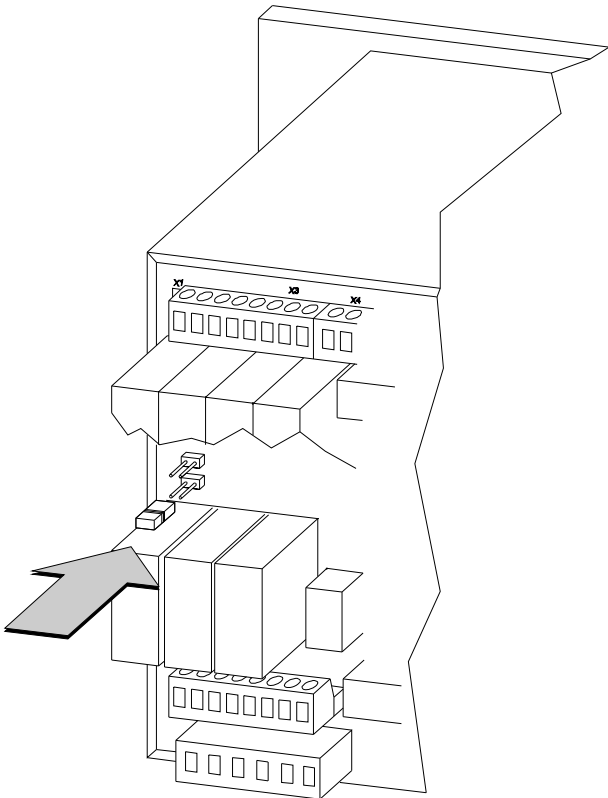

Figure 5.2: Adjustment of the additional excitation

### IMPORTANT

If the additional excitation is set too high, e.g. when the internal resistance of the dynamo windings is considerably high, it is possible that the voltage value at the windings exceeds the switching on threshold (75%). This would result in an undesired interruption of the start procedure. In such a case a smaller additional excitation should be chosen. Should even then the add. excitation be too strong, it is possible to raise the closing threshold (recommendation is 90%) per software.

If the genset has no dynamo or in case the speed is detected by an external ignition speed relay, no coding plug must be applied to X9 or X10.

Incorrect coding results in indication "Genset Running" as soon as the start command is given. The start is then stopped and followed by a new start attempt (short energizing of the start relay).

### 5.7 Speed supervision

The speed controller detects both ignition speed and overspeed.

Normally the speed is detected by measuring the generator frequency. Detection, however, via tachogenerator or pick-up is far more reliable, because there is no measuring signal available when the generator is de-energized, e.g. due to excitation failure. For detection of the speed by an external speed sensor, installation of speed module DB1 is required (additional PCB).

Speed sensors with the following operation range are suitable: 1 - 10 kHz, approx. 4 - 90 V. Calibration is possible by the parameter setting software.

### 5.7.1 Signal "Ignition Speed"/"Engine Running"

The speed is detected either by evaluating the generator frequency or optionally via pick-up or tacho generator by using speed module DB1. Normal setting of the ignitions speed switching point is 25% of the genset rated speed. When the ignition speed is reached, "Engine Running" is indicated by LED 13. Another way of detecting start-up of the engine is evaluation of the dynamo voltage or generator voltage. "Engine Running" is also signalled if the dynamo threshold voltage or the undervoltage switching point of the generator is reached.

Together with the "Engine Running" indication, time circuit "Delayed Supervision" (10 s) is started.

If there is no speed information (dynamo voltage, or pick-up, or tacho generator) after this time, although the generator voltage is available, a speed sensor defect is signalled by slow flashing LED of the first supervision circuit.

The genset keeps on running. The speed in this case is detected over the generator frequency. This is a warning fault and has a start blocking effect at the same time, i.e. running gensets will not be stopped. Only after reset of the alarm another genset start is possible.

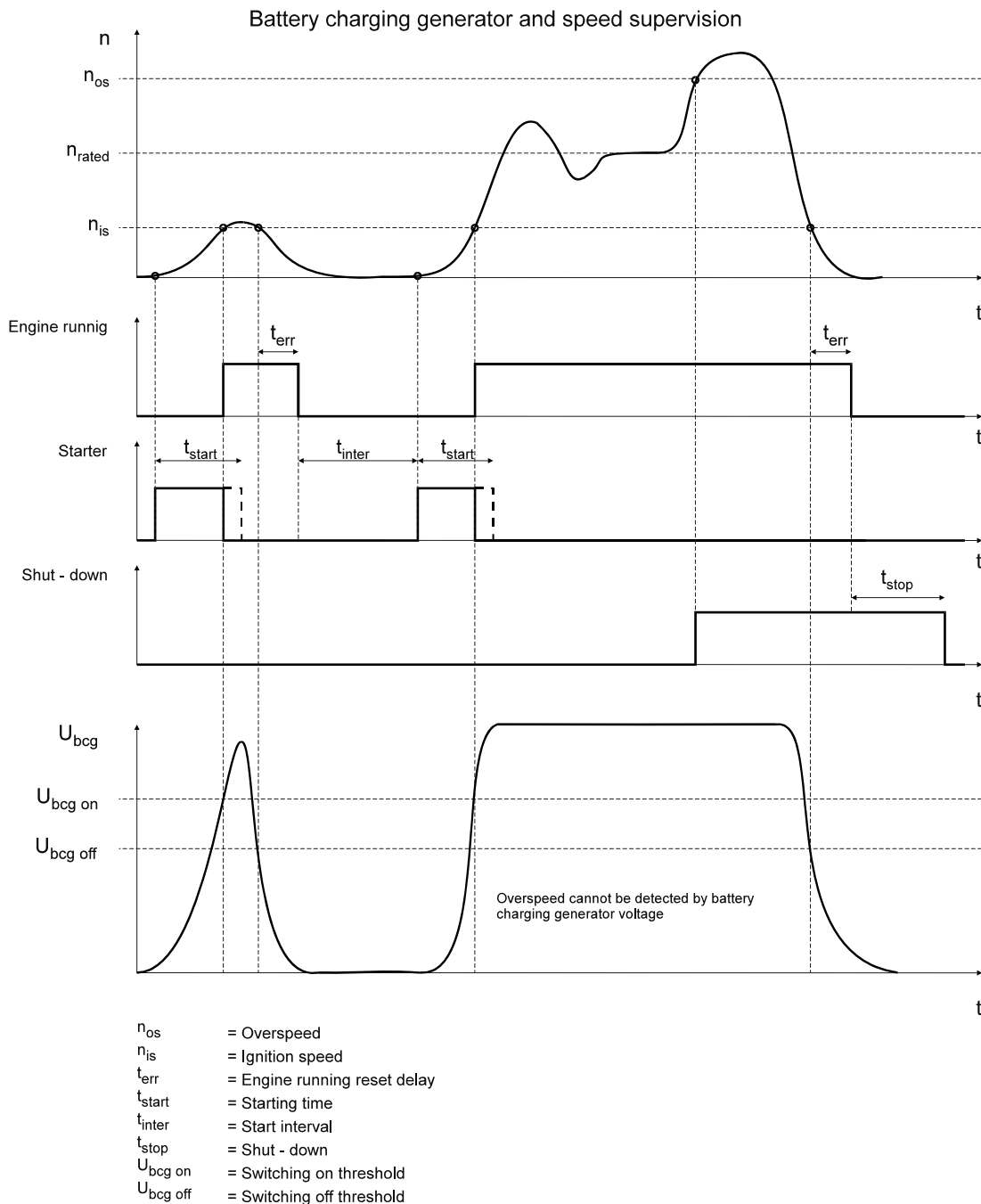

Figure 5.3: Speed measurement and supervision

## 5.7.2 Overspeed protection

As a result of overspeed the genset is stopped at 110% of the rated speed. Alarm 3 "Overspeed" has a direct stopping function.

Where module DB1 is used, the kind of speed detection (over generator frequency and DB1 or only over the DB1) has to be entered by the parameter setting software. Adjustment of the speed module DB1 for connection of the speed sensor is also realized by the software.

## 5.7.3 Total speed sensor defect

If there is no speed information neither from the dynamo nor from the generator frequency, nor from the speed sensor, the genset is instantly stopped and the fault indicated by fast flashing LED. A new start is only possible after the fault has been cleared and the alarm acknowledged by pressing push-button RESET/L.TEST.

## 5.8 Start repetition/Start failure

After three unsuccessful start attempts (normal adjustment), "Start Failure" is signalled. This is indicated by fast flashing LED of the first supervision circuit; at the same time the horn gives an acoustical alarm.

A new start attempt is only possible after acknowledgement of the RESET/L.TEST push-button.

## 5.9 Time circuits

At the rear of **NC3** switch S3 is provided. With this switch 16 different time circuit combinations can be set and additionally, in switch position F, the time circuits can individually be set by means of the parameter setting software. In all other switch positions time circuit combinations are fixed. The specific time circuit combination for each of the switch positions can be gathered from the following table. The pre-set parameters are in compliance with DIN 6280-13 (switch position 0 applies)

Time	Switch positions S3															
	0	1	2	3	4	5	6	7	8	9	A	B	C	D	E	F
Mains restoration time [s]	30	30	30	30	30	30	60*	60*	60*	60*	60*	60*	180*	180*	30*	30*
Start delay [s]	0.5	0*	0.5	0*	0.5	0.5	0.5	0*	0.5	0*	0.5	0.5	0.5	0*	0.5	0*
Max. Start preparation time[s]	120															
Pre-glowing [s]	0	0	0	0	0	0	0	0	0	0	0	0	0	0	5*	0
Starting time [s]	10															
Start interval [s]	5															
Engine running reset delay [s]	2															
Delayed supervision [s]	10															
Gen. CB Release [s]	2															
Recooling time [s]	60*	60*	180*	180*	60*	300*	60*	60*	180*	180*	60*	300*	60*	60*	60*	60*
Shut down time [s]	10															
Generator voltage tripping delay [s]	5	5	5	5	15*	5	5	5	5	5	15*	5	5	5	5	5

Table 5.5: Setting of time parameters with switch S3

Default setting

\* Deviation of standard values

## 5.9.1 Explanation of the terms used

### **Mains restoration time $t_{mar}$**

This is the time between mains recovery and change-over from generator to mains supply, i.e. release of the mains CB is present.

### **Start delay $t_{sd}$**

Means the time between mains failure and initiation of the start procedure.

### **Starting time $t_{start}$**

In operational modes AUTOMATIC and TEST the max. on-period of the starter is limited by the starting time. If the genset reaches its ignition speed before the starting time has elapsed, the starter is switched off.

### **Start interval $t_{inter}$**

This is the time between an unsuccessful start attempt and the next start possibility.

### **Engine running reset delay $t_{err}$**

If the ignition speed of the genset is exceeded during the start procedure, the genset should be accelerated up to the rated speed. If this is not the case and the ignition speed has dropped again, indication "Engine Running" remains active for the time of the engine running reset delay. After elapse of this delay, the start interval is initiated. A new start attempt follows in operational modes TEST and MANUAL.

### **Delayed supervision $t_{ds}$**

This function commences after the ignition speed has been exceeded. The delayed supervision circuits can only be activated after a start and when "Engine Running" is indicated, e.g. for oil pressure alarms.

### **Generator CB release $t_{rg}$**

During this time the generator voltage and frequency must be within admissible tolerances, otherwise the generator CB will not be released.

### **Recooling time $t_{rc}$**

For cooling down purposes the genset runs without load before it is stopped. This recooling function is not active if direct shut-down alarms occur or the genset is stopped by STOP push-button in operational mode MANUAL.

### **Recooling time at Sprinkler operation $t_{src}$**

According to VDS (German association) regulation the genset in Sprinkler systems has to run 10 min. without load for recooling purposes. If Sprinkler operation is selected, the time circuit for the normal recooling time  $t_{rc}$  (60s) is not active.

### **Shut down (time) $t_{stop}$**

Stopping of the genset is initiated after a stop command, after the recooling time has elapsed, after the ignition speed has dropped below permissible limits or upon a direct shut-down alarm. In order to guarantee complete standstill of the genset, the shut down time elapses only after the ignition speed is below the switching point or the generator voltage below the undervoltage switching point and after elapse of the switching off delay.

### **Generator voltage tripping delay $t_{vg}$**

Connection of high loads and squirrel-cage motors results in a short-term dip of the generator voltage. To avoid unintended tripping of the generator CB, the generator voltage supervision becomes delayed effective.

## 6 Supervision circuits

The **NC3** has 8 or 16 supervision circuits with LED indication and related message inscription labels. Five or 13 of these supervision circuits can be controlled from external by connecting L- (battery) to the input terminals. The other three are internal supervision circuits. The supervision circuits can be encoded for either *closed circuit principle* or *open circuit principle*.

### Open circuit principle

A signal is activated when L-(aux. voltage) is connected to the supervision input (NO contact).

### Closed circuit principle

A signal is activated when L- (aux. voltage) is disconnected from the input terminal (NC contact).

### 6.1.1 Internal supervision circuits (signals 1, 3, 6)

The first supervision circuit (signal 1) is reserved for alarms "Start Failure" and "Speed Sensor Fault". The third circuit is for alarm "Overspeed" and the sixth for alarm "Battery Voltage Failure".

## 6.1 EMERGENCY STOP (B18)

The emergency stop function can be encoded for either *closed circuit principle* or *open circuit principle*.

Switch S4 No.	Designation	Position	
		0	1
4	Emergency stop	Closed circuit	Open circuit

Table 6.1: Frequency settings

Default setting

When in closed circuit principle (default setting), alarm EMERGENCY STOP is activated by disconnection of L- (battery) at input B18. The EMERGENCY STOP command has a direct effect on the stop relay. Relays for acoustically alarm (Horn) and common alarm are activated.

The **NC3** changes into operational mode "0" (OFF). For the time the EMERGENCY STOP signal is active and not reset, LED "0" flashes slowly. If a present EMERGENCY STOP command is acknowledged via the RESET/L.TEST push-button, only the horn is switched off.

If the EMERGENCY STOP command is no longer present, the **NC3** switches back into the original operational mode after acknowledgement.

## 6.1.2 External supervision circuits

Supervision circuits 2, 4, 5 and 7 - 16 can be used for external alarms.

Two of these alarms can be coded by DIP switches, the others per software. Default setting of supervision circuits refers to normally used gensets.

Indication	7			8		
	1	2	3	4	5	6
Switch S2						
Shut-down	-	0	0	-	0	0
Delayed shut-down	-	0	1	-	0	1
Warning	-	1	0	-	1	0
Indication only	-	1	1	-	1	1
Closed circuit principle	1	-	-	1	-	-
Open circuit principle	0	-	-	0	-	-

Table 6.2: Coding possibilities of the 7th and 8th supervision circuit

 Default setting

External alarms												
NC3-x-8					NC3-x-16							
2	4	5	7	8	9	10	11	12	13	14	15	16
Softw.	Softw.	Softw.	DIP	DIP	Softw.	Softw.	Softw.	Softw.	Softw.	Softw.	Softw.	Softw.

Table 6.3: Coding of supervision circuits by software and DIP switches

### Suggested applications:

The second supervision circuit has shut-down function and is delayed monitored after start of the engine, hence it is suitable e.g. for supervision of oil pressure.

The fourth circuit has a direct shut-down effect and is suitable e.g. for temperature supervision.

The fifth circuit has a shut-down function with coded recooling time which makes it suitable for signalling overload because at overload the genset is only stopped after a certain recooling time.

The seventh circuit has a warning function and can, for instance, be used for "Lack of Fuel" alarm

The 8th supervision circuit is coded as indicating one and can indicate, for instance "Ventilation On" (status indication).

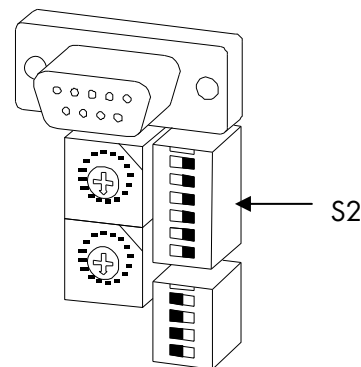

Figure 6.1: Coding of the 7th and 8th supervision circuits by DIP switch S2

### 6.1.3 Configuration of supervision circuits (Alarms)

The following table shows default setting of the supervision circuits.

Function	Supervision circuit															
	NC3-X-8 and NC3-X-16								NC3-X-16							
	2	3	4	5	6	7	8	9	10	11	12	13	14	15	16	
Input defined as alarm								●	●	●	●	●	●	●	●	
Open circuit/Closed circuit	○	–	○	○	–	○	○	○	○	○	○	○	○	○	○	
Delayed supervision	●															
Shut down	●	●	●								●				●	
Shut down with recooling				●						●				●		
Warning					●	●			●				●			
Indication							●	●				●				
Common alarm 1	●	●	●	●		●			●	●	●		●	●		
Common alarm 2					●											
Common alarm 3																
Operating delay		–			–											
Operating time (s)	0.0	–	0.0	0.0	–	0.0	0.0	0.0	0.0	0.0	0.0	0.0	0.0	0.0	0.0	

Table 6.4: Standard coding

 Internal supervision circuits

### 6.1.4 Explanations to supervision circuits

#### Input defined as alarm

Inputs for supervision circuits 1 - 8 are always reserved for alarms. However, to inputs for supervision circuits 9 - 16, also functions can be allocated; but then the inputs must not be defined for alarms. Parameters can be set per software.

#### Direct shut-down

Appart from the first-up indication, the fault is indicated by a slow flashing LED. Push-buttons HORN and RESET/L.TEST are activated. LED "Engine Running" flashes quickly and LED "Generator Voltage Available" flashes slowly. The generator CB opens and the engine is instantly stopped. The fault signal can only be reset when the fault is cleared and the stop procedure completed. Normally shut-down alarms have a red label.

#### Shut-down with recooling

This function is identical to that of a direct shut-down alarm, but here the genset is not stopped immediately. After the generator CB has been opened, the genset runs a certain time without load for recooling and is then stopped. Normally delayed shut-down alarms have a red label.

#### Warning

The fault is indicated by a slow flashing LED. Push-buttons HORN and RESET/L.TEST are activated. After acknowledgement by either of these push-buttons, the LED changes into continuous light. Only after clearance of the fault, the indication can be reset by the RESET/L.TEST push-button. By changing over into operational mode "O", a still active indicating alarm will be suppressed. Normally warning alarms have a yellow label.

### *Indication*

The LED assigned to a supervision circuit can also be used to indicate a function of the system, e.g. "Ventilator On". The indication extinguishes after there is no signal at the input. By changing over into operational mode "0", a still active indicating alarm will not be suppressed, the indication remains as long as the signal is applied to the input. Normally indicating alarms have a grey label.

### *Common alarm*

Each input can be allocated to one or more of the three common alarms. The output contacts of the three common alarm relays are defined by the Function Matrix of configurable outputs.

### *Operating delay*

For each of the alarms an operating delay is possible. This can be obtained by the parameter setting software: At first the desired operating delay has to be activated and then the operating time to be set. Until the set operating time has elapsed, proceeding of the alarm is suppressed. This function makes additional external time relays dispensable.

### *First-up indication*

The first alarm with direct shut-down function or delayed shut-down function is called "first-up indication" and is indicated by a fast flashing LED; any following shut-down alarm is indicated by a slow flashing LED. When a signal is acknowledged by push-buttons HORN or RESET/L.TEST, the respective LEDs show a continuous light, except the first-up indication, this LED flashes quickly. The first-up indication can only be reset when all the other shut-down alarms are no longer active and were reset.

### *Indication of a new alarm after acknowledgement*

After all active alarms and the first-up indication have been acknowledged by push-buttons HORN or RESET and the LEDs show continuous light, a new fault is indicated by a slow flashing LED.

## **6.2 Reset of alarm signals**

Push-button HORN can only be used to cancel an acoustical alarm; the flashing indication then changes into continuous light. Shut-down and warning alarms can only be reset by push-button RESET/L.TEST if these alarms are not active at the signal inputs.

### 6.2.1 Allocation of internal supervision circuits to common alarms 1 - 3

Function of the supervision circuits as well as their allocation to the different common alarms can be defined by ON or OFF per parameter setting software.

	Function	Common Alarm 1	Common Alarm 2	Common Alarm 3
Start failure	–	●		
Start preparation failure	On	●		
Mains restoring failure	On	●		
Generator voltage failure	–	●		
Defect of speed sensor /V-belt (ON / OFF)	On	●		
Complete speed failure	–	●		
Synchronization failure	Off	●		

Table 6.5: Allocation of internal supervision circuits to common alarms 1 - 3

### 6.2.2 Alarm time

For all shut-down and warning alarms the alarm output (Horn) is activated for the set alarm time  $t_{\text{Alarm}}$  (default setting = 302 s). By using the parameter setting software this time can be changed.

## 7 Inputs

### 7.1 Function matrix for configurable inputs

Switching on and off of special functions, e.g. "Emergency Off", "Sprinkler Operation", but also remote operations like changeover of operational modes, can be realized by the Function Matrix of configurable inputs. Inputs C17 - C24 are as standard reserved for alarms and these setting can only be altered by using the parameter setting software.

Function	Input											
	B24	C17	C18	C19	C20	C21	C22	C23	C24	D1	D2	D3
Input signal defined as alarm (no.)		•	•	•	•	•	•	•	•			
Emergency start	•											
Parallel operation										•		
Start/CB control, generator											•	
Sprinkler operation												•
Operation mode selection blocked												
External resetting of alarms												
External Reset/LED Test												
External selection of operating mode												
Selection: AUTOMATIC												
Selection: TEST												
Selection: MANUAL												
Selection: Off												

Table 7.1: Function matrix for configurable inputs

### 7.2 Emergency start

The emergency stop function is activated as default setting and in detail explained in chapter 5.5.

### 7.3 Parallel operation

For mains parallel operation with a single genset the NC3-1 is provided with two function inputs (D1 and D2). Synchronization has to be realized by an external synchronizing facility. Safe and reliable synchronization can be achieved by appropriate synchronizing units from our Electronic Device Program. Parallel operation of several gensets is possible by using controller type NC3-2.

#### Important:

By operating errors during the synchronizing procedure severe damage can be inflicted on the system. Therefore it is imperative that commissioning work is done by skilled personnel. Experienced engineers from our Service Division are available for these kind of jobs.

#### 7.3.1 Start without mains failure

The purpose of automatic controller for AMF operation NC3-1 is in short, to ensure start of the standby generating set and supply of consumers in case of mains failure. As soon as mains voltage is available or the mains has recovered, the genset should be stopped and the consumers automatically changed over to mains supply again.

In mode AUTO start of the genset is normally controlled either by an external voltage supervision relay and input B8 or by the internal voltage supervision (only provided for NC3-1); B7 and B 8 have to be bridged then.

There are three ways to start the genset for parallel operation:

1. In operational mode AUTOMATIC by connecting L- of input D2
2. By selecting mode TEST
3. In operational mode MANUAL by pressing the START push-button

### 7.3.2 Switching in parallel

In emergency power operation the mains CB and generator CB are interlocked by the NC3 software. By connecting L- (aux. voltage) to terminal D1 (parallel operation) the internal CB interlocking is disabled. When the generator voltage is within the permissible range, the generator CB is released. The external CB interlocking (by aux. contacts of the CBs/power contactors), however, prevents switching-on of the generator CB until the external interlocking contacts are bridged by the synchronizing contact of the synchronizing unit.

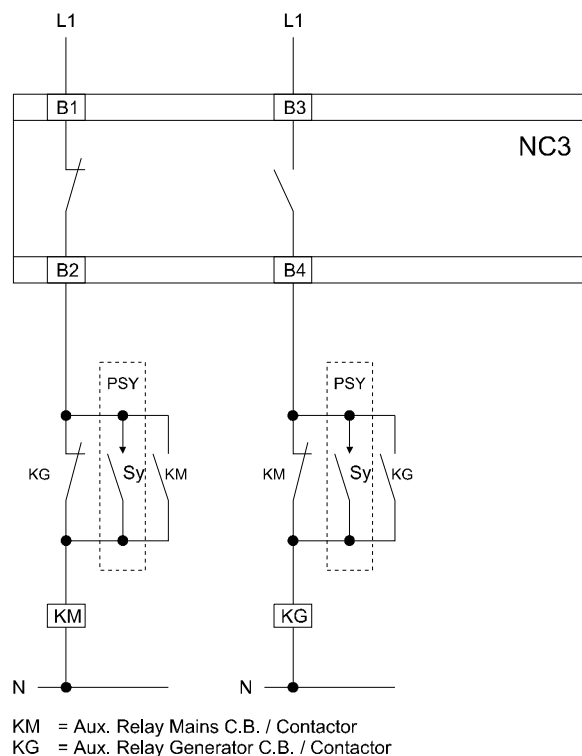

Figure 7.1: Connection example for mains parallel operation

Because synchronizing facilities normally give synchronizing pulses only, a latched contact of the generator contactor KG (see connection diagram) has to bridge the interlocking contact of the mains contactor after synchronization is successfully completed.

For automatic synchronization our automatic synchronizing unit PSY can be recommended. For manual synchronization, however, a synchronisation check relay has to be used, e.g. our type SY/SP.

### **7.3.3 Genset load test without power supply interruption**

Starting and synchronizing of the genset is done as described in chapters 7.3.1 and 7.3.2.

After switching in parallel, the parallel operation command at input D1 (L-) is de-activated by an aux. contact of the generator CB and so release of the mains CB is disabled. The generator CB remains switched on. The entire consumer load is now taken over by the genset.

### **7.3.4 Automatic changeover after AMF operation**

The changeover from emergency power operation to mains operation after mains restoration is not without interruption. Should, however, uninterrupted changeover to mains supply be requested, the genset must remain in operation until the synchronization is completed. Duly operation of the genset (output B15/B16) and existence of mains voltage (output B7) has to be checked by using an external circuit. If both conditions are met, the external circuit has to connect L- to input D2 (maintaining the genset in operation). Afterwards the internal interlocking of the CBs has to be disabled by connecting L- to input D1. After synchronization is completed, L- has firstly to be disconnected from D2 and then from D1.

## 7.4 Sprinkler operation

The requirements to Sprinkler systems is such that always a minimum amount of water has to be stored at a certain pressure. Normally electrical pumps or pump sets are used for this function.

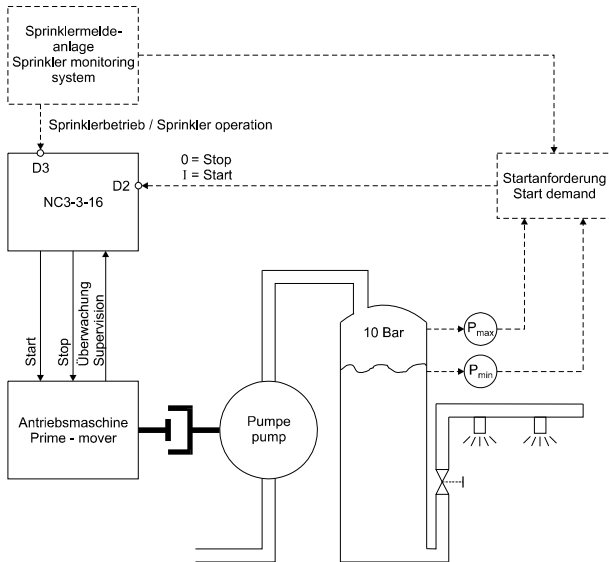

Figure 7.2: Sprinkler system with pump set

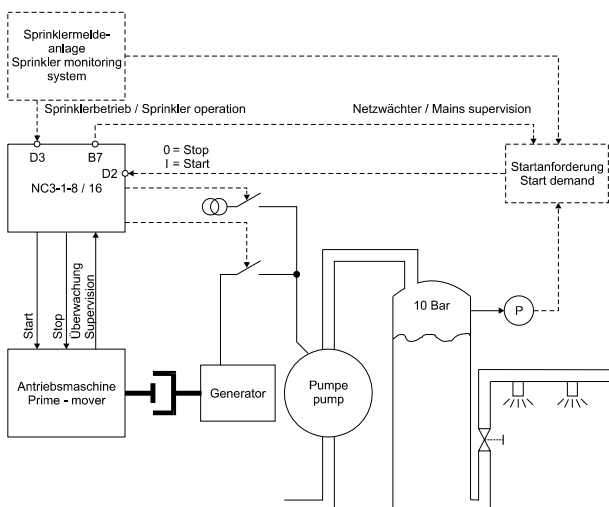

Figure 7.3: Sprinkler system with electrical pump

The "Sprinkler operation" mode is activated by input D3, but the genset is not started yet. Sprinkler operation is indicated by a fast flashing LED of the previously selected mode. For Sprinkler operation the number of coded start attempts is doubled (default setting 2 - 3). Start requirement is controlled by an external logic. Start criteria are for instance: Sprinkler alarm, water pressure and mains failure. A start is initiated by connecting L- to input D2.

Stopping of the genset is achieved by de-activating input D2. In Sprinkler operation (L- at D3) the genset stops after a prolonged recooling time of  $t_{sfc} = 599s$ .

Coded shutdown alarms do not cause the genset to stop but are indicated like coded warning alarms.

By VDS regulations a different starter battery has to be selected for each start attempt. This function can be activated per parameter setting software (see chapter 8). The starter battery is changed always after half of the start interval  $t_{inter}$  has elapsed (see chapter "Start cycle").

NC3-3-16 automatic controller is designed for Sprinkler systems with pump sets. For Sprinkler systems with electrical pumps type NC3-1-16 is used (see chapter 8).

## 7.5 Remote control

Operational modes can be changed from external by push-buttons or control pulses (about 3s L-). For this purpose all inputs shown on the Function Matrix can be used, provided they are not reserved for alarms or are not used for other functions. Default settings have to be changed accordingly. As it can be seen from the Function Matrix of configurable inputs, operational modes can be allocated to any of the inputs (see Table 7.1). Change of operating modes is possible either direct from the device or via inputs (remote).

If function "External Selection of Operational Modes" is allocated to an input to which a continuous signal is applied (L-), change of modes is only possible via function inputs.

Selection of functional modes from the device as well as via function inputs can be blocked. To achieve this, function "Blocking of Operational Mode Selection" has to be allocated to an input and L- to be connected to that input. This is normally done by a key switch.

De-activating of alarm outputs (Horn), resetting of alarms as well as lamp test are also possible via inputs.

Function of remote Reset and Lamp Test is identical with that of push-button RESET/L.TEST at the front of the controller. An input signal of about 3 s results in test of all LEDs. Functions Reset or Lamp Test can alternatively be switched off.

## 8 Outputs

The NC3 has a Matrix for adjustable outputs on which controller functions can freely be allocated to outputs per parameter setting software.

### 8.1 Definition and switching capacity of configurable outputs

When allocating outputs it is important to pay due attention to the max. current loading capacity of contacts!

Output	NC3-1-x and NC3-1-16						NC3-2-x	
	A1	A2	A3	A4	A5	A6	A7	A8
Max. ohmic load (A)	2	2	16	2	16	16	2	16
Base contact	D7	D5	C11	C9	C1	C3	L	B1
NO contact	D8	D6	C12		C2	C6	B7	B2
NC contact		D4		C10	C7			

Table 8.1: Definition and switching capacity of configurable outputs

### 8.2 Function matrix of configurable outputs

Output	NC3-1-x and NC3-1-16						NC3-2-x	
	A1	A2	A3	A4	A5	A6	A7	A8
Stop open circuit						●		
Stop closed circuit					●			
Pre-glowing			●					
Common signal 1				●				
Common signal 2		●						
Common signal 3	●							
Generator voltage fault								●
Battery selection								
Sprinkler operation								
Signal test							●	
Reset								
Load 2 release								

Table 8.2: Function matrix of configurable outputs

#### 8.2.1 Common alarm

When allocating a common alarm to an output it has to be observed that for the signal of this alarm the closed circuit principle applies, i.e. the output relay energizes when aux. voltage is connected and de-energizes when a fault occurs.

### 8.2.2 Load stage control

Prime movers of gensets, especially turbocharged diesel engines, very often do not permit that the total consumer load is connected at the same time. Taking this technical feature into account, a two-stage load connection is possible with the NC3 controller. Load of the first stage is connected when the generator CB is released. The load connection time  $t_{lz}$  is started by the generator CB check-back signal at input B6. After this time has elapsed, output for load stage 2 is activated. The connection function for load stage 2 has to be allocated to an output (Output Matrix).

### 8.2.3 Alarm output

External warning and shut-down faults are signalled to output C8. All warning and shut down alarms are operating on this output. Normally this output is used for connection of the horn, but it can also be utilized for controlling a common alarm relay.

The relay connected to output C8 can be reset by push-buttons HORN or RESET/L.TEST. If this output relay is not manually reset, it will be automatically reset after the alarm time  $t_{Alarm}$  has elapsed. (Default setting = 302 s)

### 8.2.4 Common alarm 2/Battery voltage too low

Potentialfree output D4/D5 is intended for signalling common alarms. Which of the alarms should have an effect on this output can be defined by using the parameter setting software.

Normally alarm "Battery Voltage Too Low" is designated to this output. When the aux. voltage is available and the battery voltage in the permissible range, the relay is energized; contact D4/D5 is open (closed circuit principle). In case the aux. voltage fails, the alarm is signalled (contact D4/D5 closed).

## 9 Survey of Parameters

A variety of applications is covered by the parameter setting facilities at the unit, e.g. by means of switches and coding plugs. Additionally the parameter setting software *NC3-Soft* can be used for specific solutions and more accurate adjustment to the genset.

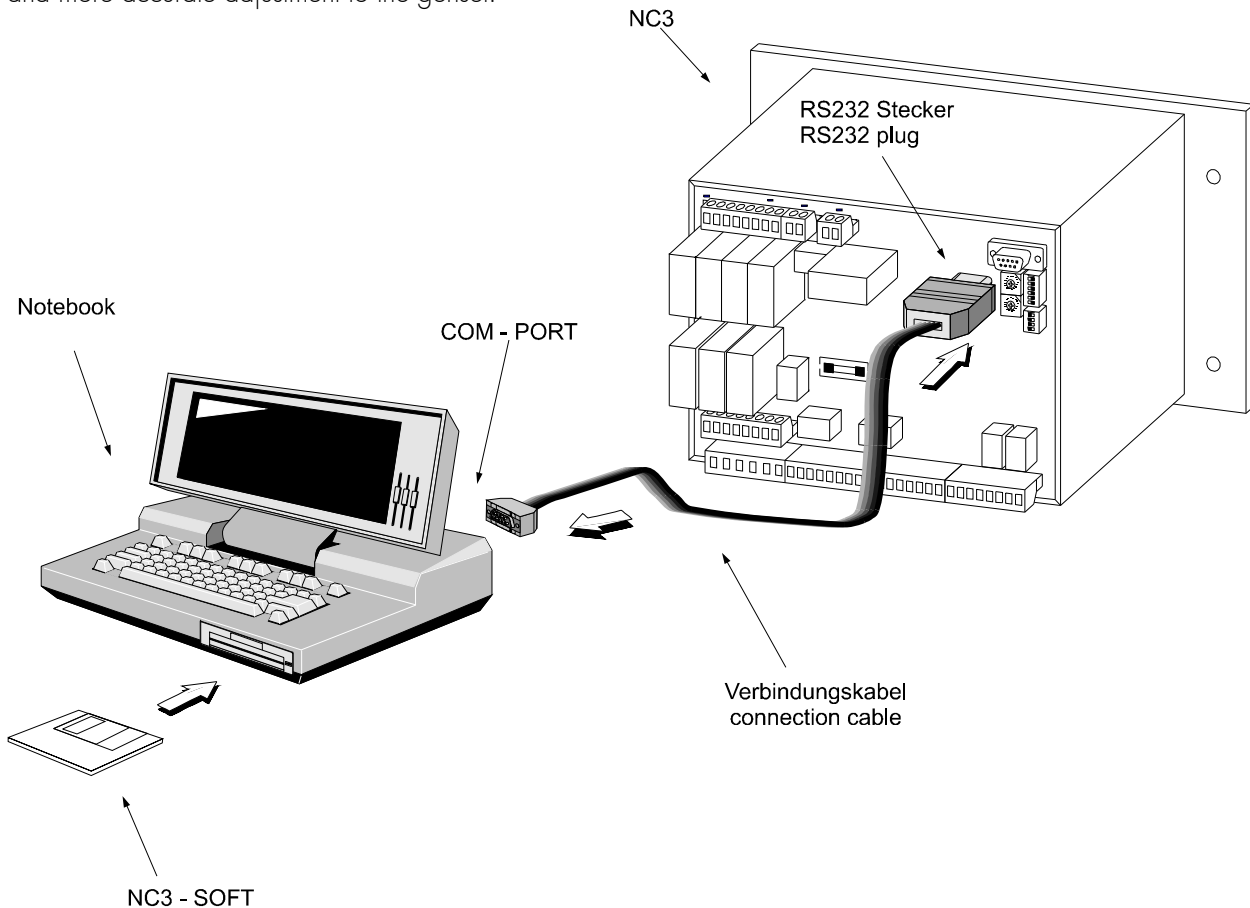

Figure 9.1: Connection via notebook

### 9.1 Possibilities for parameter setting at the unit

The following parameters can be set direct at the unit:

#### Mains:

- Measuring methods 3-phase
- Rated voltage
- Frequency supervision element ON/OFF
- Rated frequency

#### Generator:

- Measuring methods 2-phase (L1, L2)
- Rated voltage
- Frequency supervision element ON/OFF
- Rated frequency
- Generator voltage tripping delay

#### Genset:

- Battery voltage 12 V/24 V/Low/High
- Start delay
- Recooling time

#### Signals:

- Open circuit principle/Closed circuit principle
- Delayed supervision
- Direct stop
- Stop with recooling time
- Warning/Indication

## 9.2 Possibilities for parameter setting by means of software

The following parameters can be set by using parameter software *NC3-Soft*. Explanation of these parameters can be found in the Online guide of the parameter software.

### Mains:

- Rated voltage
- Undervoltage
- Overvoltage
- Minimum voltage for evaluating the frequency
- Static and dynamic frequency deviations
- Operating and release time of the frequency supervision element
- Operating and release time of the voltage unbalance supervision element
- Supervision of mains recovery (ON/OFF)
- Mains switching back time

### Generator:

- Rated voltage
- Undervoltage
- Overvoltage
- Frequency determined from the generator voltage or speed module
- Minimum voltage for evaluating the frequency
- Static and dynamic frequency deviations
- Operating and release time of the frequency supervision element
- Release of generator CB and generator voltage tripping delay
- Additional voltage supervision element:
  - Supervision ON/OFF
  - Voltage deviation
  - Voltage control time

### Genset:

- Battery voltage switching points
- Battery- over- and undervoltage
- Tripping delays at battery undervoltage
- On and Off threshold of dynamo voltage
- Ignition speed
- Overspeed
- Overfrequency either determined by DB1 or both from generator frequency and by DB1
- Calibration of speed sensor (with DB1 only)
- Max. start attempts
- Start delay

- Starting timing
- Start interval
- Switching off delay
- Delayed supervision
- Mains restoration time
- Recooling time
- Stopping time

### Signals:

- Configuration of alarm signals
  - Open circuit/closed circuit principle of signal inputs
  - Delayed supervision
  - Direct shut-down
  - Shut-down with recooling time
  - Warning/Indication
  - Common alarm
  - Energizing delay signals 2-16
- Operating time signals 2-16
- Internal signals about common alarms
  - Start failure
  - Mains recovery fault
  - Generator voltage failure
  - V-belt rupture/Speed sensor defect
  - Total speed sensor defect
- Alarm duration

### Input matrix

### Output matrix

## 9.3 Indication of actual measuring values

In addition to parameter setting, the software *NC3-Soft* can also be used for indication of the following actual measuring values:

- Mains voltage
- Mains frequency
- Generator voltage
- Generator frequency
- Speed
- Battery voltage
- Dynamo voltage

## 10 Application for pump sets (NC3-3)

The automatic controller for pump sets NC3-3-16 has no function for control of mains and generator CBs and a generator voltage supervision is not included either. Speed supervision can only be realized by speed module DB1 (see Figure 10.2).

By the integrated mains supervision as well as by the level control, the pump set is started and stopped.

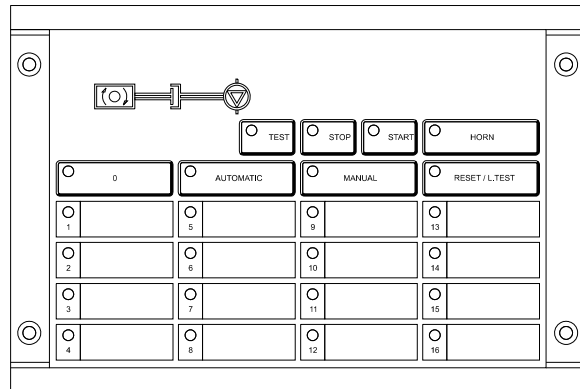

Figure 10.1: Pump set controller NC3-3-16

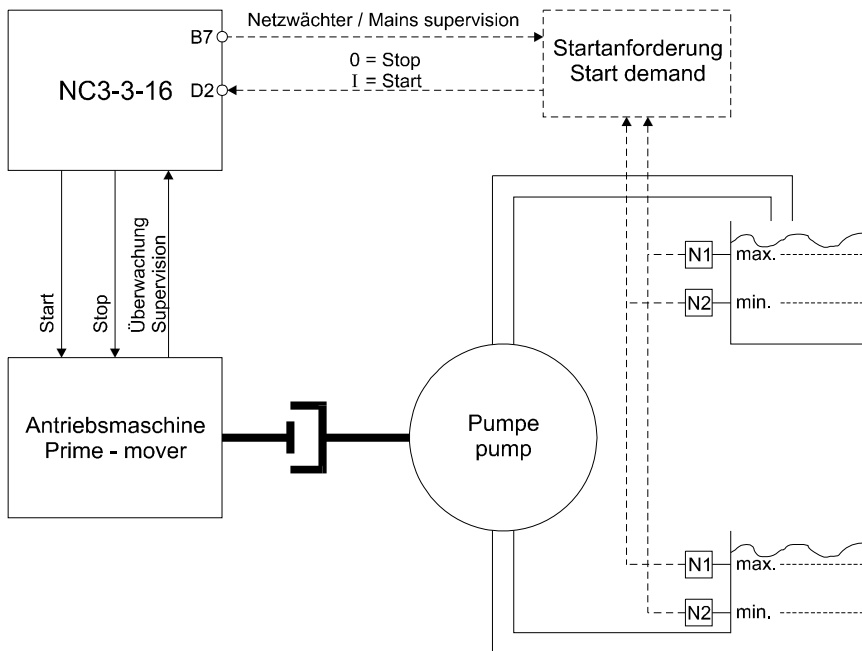

Figure 10.2: Scheme pump set control

## 11 Installation

The **NC3** is designed for flush-mounting in the switch-gear panel. Any installation position is possible. The necessary screws are delivered together with the device.

### Note:

If IP54 applies for the switchboard, a rubber sealing frame has to be placed under the front frame before the **NC3** is installed (see order form).

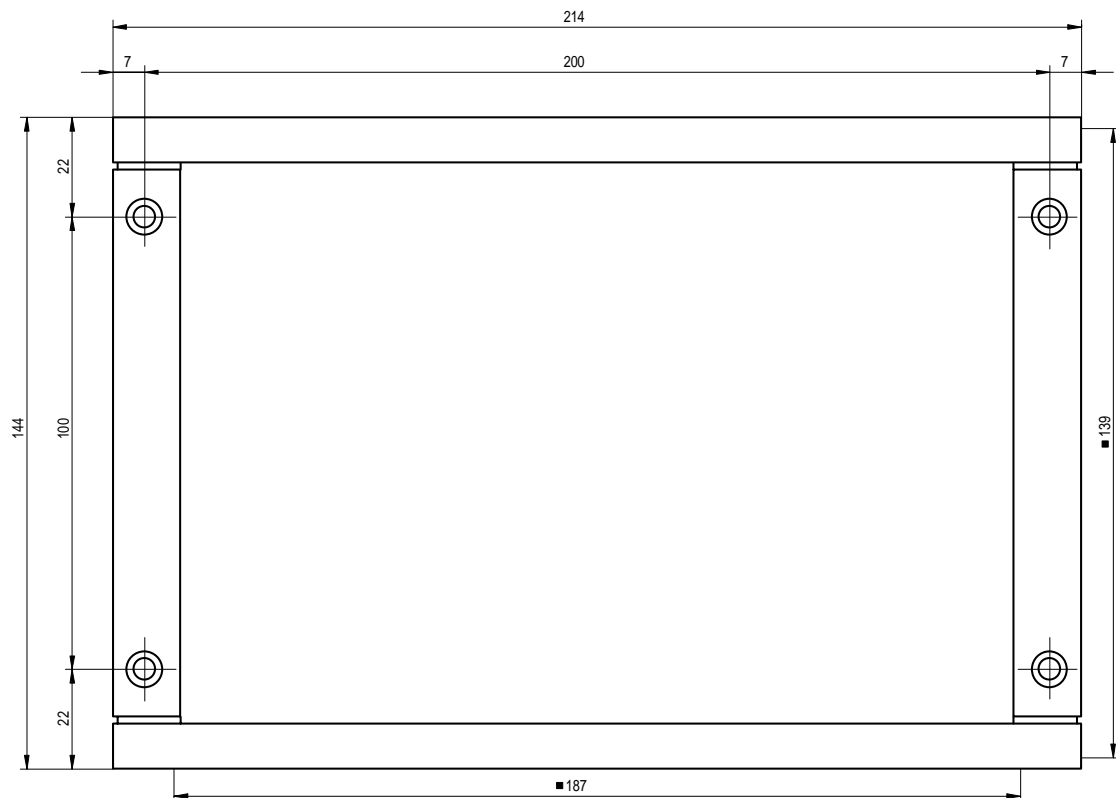

Figure 11.1: Dimensions of the NC3

Installation depth: 161 mm

■ Panel cut-out (B x H): 187 mm x 139 mm

## 12 Technical Data

### General Data

Type:	<b>NC3</b>
Design:	flush panel mounting
Duty:	continuous operation
Connecting terminals:	max. 2.5 mm <sup>2</sup>
Maintenance:	none

### Input circuits

Aux. voltage:	8 - 35 V/DC
Power consumption:	7.5 W
Generator voltage:	50 bis 500 V/AC
Mains voltage:	50 bis 500 V/AC
Rated frequency:	50/60 Hz codable
Frequency measuring tolerance:	±0.1 Hz
Voltage measuring tolerance:	2% from the rated voltage
Battery voltage supervision:	8 - 35 V/DC
Tolerance of battery voltage supervision:	2% at 24 V
Dynamo voltage:	0 - 40 V/DC
Supervision circuits:	Add. Excitation, strong (60 Ω)/ weak (120 Ω) codable 3 internal, 5 external

### Output circuits

For the following relay contacts, the max. contact voltage is 40 V/DC:

C1/C2	- shut-down, closed circuit (16 A)
C3/C4	- starter (16 A)
C3/C6	- shut-down, open circuit (16 A)
C3/C8	- horn (16 A)
B9/B10	- genset running (16 A)
C9/C10	- battery voltage too low/common alarm (2 A)

For the following relay contacts, the max. contact voltage is 230 V/AC:

B1/B2	- mains CB (16 A)
B3/B4	- generator CB (16 A)

Contact material:	AgCdO
-------------------	-------

### Tests and Design Standards

- Radio interference suppression as per VDE 871, class B
- Impulse voltage test as per VDE435, part 303, class 3
- High frequency interference test as per VDE 435, part 303, class 3
- Creeping distance and clearance as per VDE 110, part 2
- Electrical fast transient (burst) test as per VDE 0834, part 4, intensity factor 4
- Electrostatic discharge test as per VDE 0834, part 3, intensity factor 3
- Radiated electromagnetic field test as per VDE 0843, part 3, intensity factor 3

### Important!

Prior to voltage test of the switchboard the protective earthing conductor of the **NC3** has always to be disconnected from the protective earthing conductor of the switchboard, otherwise there is the danger of damaging the device.

### Climatic Conditions

Min./Max. ambient temperatures

when stored: -40°C up to +75°C

In operation: -20°C up to +70°C

Humidity resistance: Class F acc. to DIN 40040, tested as per DIN IEC 68, part 2-3 (56 days 40°C and 93% r.h.)

### Housing, Dimensions, Weight and Installation

Design:	for flush panel mounting
Front panel material:	aluminium with foil push buttons
Housing material:	Makrolon (self-extinguishing)
Dimensions (w x h x d):	(w x h x d) 214 x 144 x 165 mm
Panel cut-out:	(w x H) 187 x 139 mm
Housing installation:	fixed by screws
Installation position:	any
Weight:	ca. 1.2 kg
Protection class, front panel:	IP54

This manual is valid for controller software version from P1.08 onwards (see type plate of controller).

It is our endeavour to provide a product always in line with the latest developments, i.e. technical or constructional changes are possible and are in the interest of our customers. They are not subject to notification.

### 13 Order form

When ordering the *NC3* please use the following form and mark according to your application.

If no specific information is given, the device is coded and labelled as per standard.

Language:

German       English

Standard labelling

1	STARTFAILURE	R	5		R	9		R	13		R
		G			G			G			
		Gr			Gr			Gr			
2		R	6	BATTERY VOLTAGE TOO LOW	R	10		R	14		R
		G			G			G			
		Gr			Gr			Gr			
3	OVERSPEED	R	7		R	11		R	15		R
		G			G			G			
		Gr			Gr			Gr			
4		R	8		R	12		R	16		R
		G			G			G			
		Gr			Gr			Gr			

(R = red, G = yellow, Gr = grey)

Internal signals are shown in the grey sections which cannot be assigned to other signals.  
Additionally are supplied: 9 red, 4 yellow and 8 grey labels as well as 3 coding plugs.

Labelling of fault signals acc. to DIN 6280-13 (extra charge)

1	STARTFAILURE	R	5	OVERLOAD SHORT CIRCUIT	R	9		R	13		R
		G			G			G			
		Gr			Gr			Gr			
2	OIL PRESSURE TOO LOW	R	6	BATTERY VOLTAGE TOO LOW	R	10		R	14		R
		G			G			G			
		Gr			Gr			Gr			
3	OVERSPEED	R	7	LACK OF FUEL	R	11		R	15		R
		G			G			G			
		Gr			Gr			Gr			
4	OVER- TEMPERATURE	R	8		R	12		R	16		R
		G			G			G			
		Gr			Gr			Gr			

(R = red, G = yellow, Gr = grey)

Additionally are supplied: 5 red, 4 yellow and 8 grey labels as well as 3 coding plugs.

Labelling according to specification (extra charge):

1	R	5	R	9	R	13	R
	G		G		G		
	Gr		Gr		Gr		
2	R	6	R	10	R	14	R
	G		G		G		
	Gr		Gr		Gr		
3	R	7	R	11	R	15	R
	G		G		G		
	Gr		Gr		Gr		
4	R	8	R	12	R	16	R
	G		G		G		
	Gr		Gr		Gr		

(R = red, G = yellow, Gr = grey)

If other than standard labels are required (additional price on request), please enter the text accordingly.  
The section size is 34 x 13mm.

**Further Details:**

Add. excitation:  strong       weak       No dynamo

Protect. class IP54:  no       Yes (rubber sealing frame will be provided)

Standard coding; please mark the desired changes with a cross

**Note:**

If IP54 applies for the switchboard, a rubber sealing frame has to be placed under the front frame before the **NC3** is installed.

### 13.1 Order code

Gen-set controller	<b>NC3-</b>			
For emergency power and mains parallel operation with control for mains and generator C.B.	<b>1</b>			
As gen-set controller with control for generator C.B.	<b>2</b>			
with 8 supervision circuits		<b>8</b>		
with 16 supervision circuits		<b>16</b>		
Standard				*
Additional with: Parallel control of front panel buttons by digital inputs				<b>-P<sup>1</sup></b>

\* Please leave box empty if option is not desired (no extra charge)

<sup>1</sup> device variants with 16 supervision circuits on request

Gen-set controller	<b>NC3-3-16</b>
As control for pump set with 16 supervision circuits (Order DB1 required)	

### 13.2 Accessories

Speed module for NB2 and NC3	<b>DB1</b>
------------------------------	------------

Remote signal module for NC3	<b>FC1-8-24</b>
with 8 relay contact outputs for remote fault indication Supply voltage 24 V/DC	

Diagnosis and setting software with RS 232 cable (2m)	<b>NC3-SOFT</b>	
German		<b>-D</b>
English		<b>-E</b>

Connecting cable for setting software (for replacement) RS 232 cable (2m) – belongs to NC3 – SOFT	<b>NC3-RS232</b>
--	------------------





**Woodward SEG GmbH & Co. KG**

Krefelder Weg 47 · D – 47906 Kempen (Germany)

Postfach 10 07 55 (P.O.Box) · D – 47884 Kempen (Germany)

Phone: +49 (0) 21 52 145 1

**Internet**

Homepage <http://www.woodward-seg.com>

Documentation <http://doc.seg-pp.com>

**Sales**

Phone: +49 (0) 21 52 145 635 · Telefax: +49 (0) 21 52 145 354

e-mail: [kemp.electronics@woodward.com](mailto:kemp.electronics@woodward.com)

**Service**

Phone: +49 (0) 21 52 145 614 · Telefax: +49 (0) 21 52 145 455

e-mail: [kemp.pd@woodward.com](mailto:kemp.pd@woodward.com)